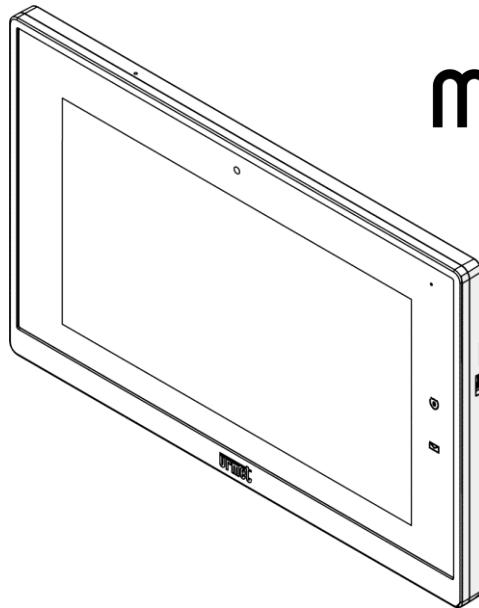

VIDEOCITOFONO MAX 10"
10" MAX VIDEO DOOR PHONE
MONITEUR MAX 10"
VIDEOINTERFONO MAX 10"
10"-MAX-VIDEOSPRECHANLAGE
MAX-BEELDINTERCOM 10"

Sch./Ref. 1717/21

**max**

GUIDA RAPIDA PER L'UTILIZZO
QUICK USER'S GUIDE
GUIDE RAPIDE D'UTILISATION
GUÍA RÁPIDA DE USO
KURZANLEITUNG
SNELGIDS

Indice / Index / Sommaire / Índice / Inhalt / Inhoudsopgave

ITALIANO	3
ENGLISH	9
FRANÇAIS	15
ESPAÑOL	21
DEUTSCH	27
NEDERLANDS	33

DESCRIZIONE DEI COMPONENTI DESCRIPTION OF COMPONENTS DESCRIPTION DES COMPOSANTS DESCRIPCIÓN DE LOS COMPONENTES BESCHREIBUNG DER KOMPONENTEN OMSCHRIJVING VAN DE ONDERDELEN

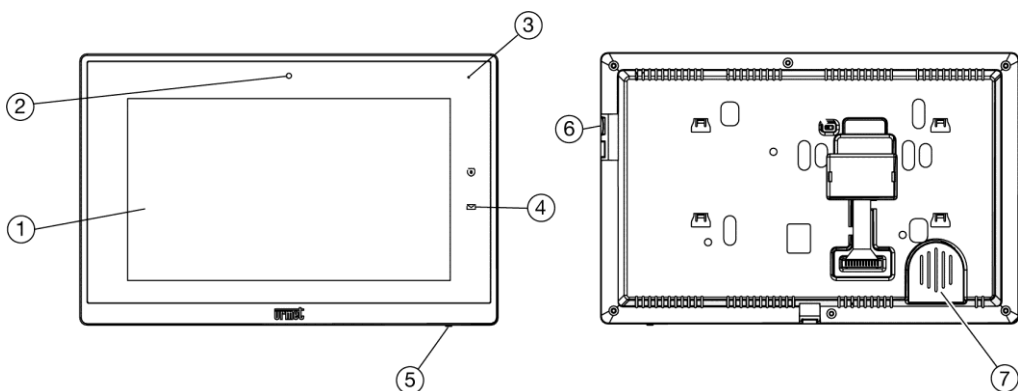

1. Display touchscreen 10" / 10" *touchscreen display* / Écran tactile 10" / Pantalla táctil 10" / 10"-Touchscreen-Display / 10" *Touchscreen-display*
2. Webcam 2Mpx / Webcam 2Mpx / Webcam 2Mpx / Cámara web 2Mpx / Webcam 2Mpx / Webcam 2Mpx
3. Microfono / *Microphone* / Micro / *Micrófono* / Mikrofon / *Microfoon*
4. Led blu per segnalazioni notifiche / *Blue LED for alerts* / LED bleue pour les notifications / *Led azul de indicación de notificaciones* / Blaue Led für Meldungen und Benachrichtigungen / *Blauw ledlampje voor berichtenmelding*
5. Pulsante Home / *Blue Home button* / Bouton Home / Tecla de Inicio / Home-Taste / Home-toets
6. Micro SD Card / *Micro SD Card* / Micro-carte SD / *Tarjeta micro SD* / Mikro-SD-Karte / *Micro SD-kaart*
7. Altoparlante / *Speaker* / Haut-parleur / *Altavoce* / Lautsprecher / *Luidspreker*

ITALIANO

FUNZIONALITÀ

COME ACCENDERE LO SCHERMO E ACCEDERE ALLE VARIE FUNZIONI

- Toccare lo schermo in un punto qualsiasi, oppure
- Premere il pulsante (5) in basso a destra sotto al videocitofono, che farà apparire la Home Page.

La Home Page di default è l'applicazione Videocitofonia,

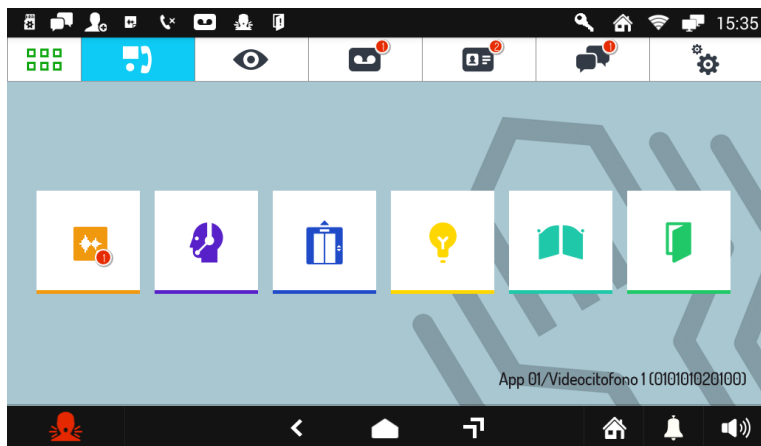

In basso a destra è possibile visualizzare le seguenti informazioni:

App 01: Indica il nome dell'appartamento in cui è presente il videocitofono.

Videocitofono 1: Indica il nome che è stato assegnato al videocitofono in fase di configurazione.

010101020100: Codice identificativo del videocitofono.

Dalla pagina Videocitofonia è possibile accedere alle seguenti funzioni videocitofoniche:



Registrare brevi messaggi audio (Post-It).



Chiamare il centralino.



Attivare una funzione ausiliaria, ad esempio l'attivazione di un relè per permettere di abilitare l'ascensore a raggiungere il piano desiderato (se l'impianto Ipercom è opportunamente predisposto).



Attivare una funzione ausiliaria, ad esempio l'accensione delle luci scala (se l'impianto Ipercom è predisposto).



Aprire il cancello dell'eventuale passo carraio.



Aprire la porta.

Per cambiare l'applicazione di default toccare l'icona , posizionata in alto a sinistra, che consente

di accedere alla Top Page, quindi toccare l'icona Configurazione  e infine il menù Home Page.

Le altre icone di navigazione della barra superiore permettono di:



Visualizzare le immagini riprese dalle telecamere presenti nell'impianto.



Visualizzare i messaggi audio-video registrati (Segreteria videocitofonica).



Visualizzare la Rubrica dei Contatti e il registro delle chiamate.



Inviare messaggi di testo (Chat).



Variare le impostazioni audio/video del videocitofono e/o la lingua di funzionamento.

Le icone della barra inferiore permettono di :



Tornare alla pagina precedente.



Tornare alla Home Page.



Andare alla pagina che elenca le applicazioni aperte di recente.



Inviare una segnalazione di allarme panico (funzione possibile se nell'impianto Ipercom è presente un centralino di portineria opportunamente configurato).



Silenziare la chiamata (Mute) al videocitofono per un periodo di tempo impostabile a piacere.



Modificare il volume della chiamata.



Impostare i seguenti stati del dispositivo:
In casa / Segreteria / Deviazione / Remoto (alternativi fra loro).

COME INTERPRETARE LE SEGNALAZIONI

La barra superiore dello schermo mostra le informazioni di stato.



Micro SD Card inserita.



Presenza di un Messaggio di testo (Chat) non letto.



Richiesta di nuovo contatto.



Presenza di un Post-it non ascoltato.



Chiamata persa.



Presenza di un videomessaggio non letto.



Allarme panico inviato/annullato.



Presenza porta aperta



Apertura automatica della porta (se la funzione è attivata).



In casa / Segreteria / Deviazione / Remoto (alternative tra loro).



Collegamento WiFi attivo o alla 2ª LAN (alternative tra loro).



Collegamenti LAN alla rete Ipercom.



Ora.

COME NAVIGARE TRA LE APPLICAZIONI

Le varie applicazioni sono accessibili dalla Top Page, toccando la relativa icona.

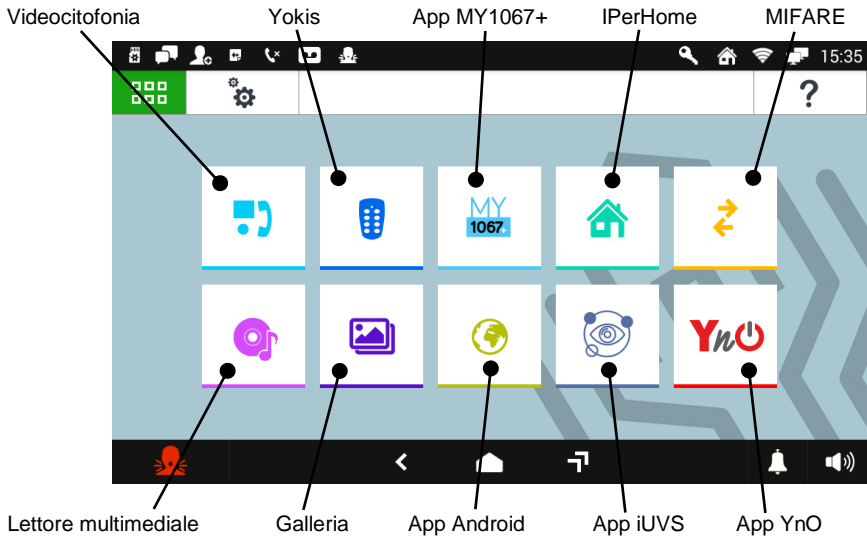

Esempio di Top Page

- **Videocitofonia:** vedere capitolo “COME RISPONDERE A UNA CHIAMATA PROVENIENTE DALL’ESTERNO”.
- **Yokis:** vedere capitolo “COME ATTIVARE UN COMANDO YOKIS”.
- **App MY1067+:** applicazione che permette di visualizzare lo stato della centrale antintrusione 1067 presente nell’impianto.
- **IPerHome:** applicazione che permette di accedere e gestire la domotica IPerHome.
- **MIFARE:** applicazione che permette di registrare gli ingressi e le uscite dall’appartamento.
- **Letture multimediale:** applicazione che permette la riproduzione di file audio se è presente la scheda SD.
- **Galleria:** applicazione che permette la visualizzazione delle immagini sul display del videocitofono.
- **App Android:** permette di accedere a tutte le App e Widgets Android preinstallati.
- **App iUVS:** permette di visualizzare le immagini provenienti dalle telecamere presenti nell’impianto.
- **App YnO:** applicazione che permette di gestire la domotica Yokis.

Per maggiori dettagli scaricare il **Manuale utente completo** scansionando il QR Code riportato alla fine della sezione.



Per tornare alla Home Page da qualsiasi pagina visualizzata toccare l'icona  posta al centro della barra inferiore.

COME SPEGNERE LO SCHERMO

Per spegnere lo schermo premere il tasto (5) del videocitofono Sch. 1717/21 oppure attendere il timeout impostato nel menù Configurazione.

COME RISPONDERE A UNA CHIAMATA PROVENIENTE DALL’ESTERNO

Quando il videocitofono Sch. 1717/21 riceve una chiamata videocitofonica esterna squilla e accende lo schermo, che è normalmente spento. Il videocitofono visualizzerà sul display l’immagine del chiamante.

Se nell’appartamento sono presenti più videocitofoni quando si riceve una chiamata solo il videocitofono Master visualizzerà l’immagine del chiamante. Per visualizzare l’immagine del chiamante su un videocitofono Slave premere la dicitura “**Tocca qui per vedere chi ti sta chiamando**” visualizzata sul display del videocitofono.

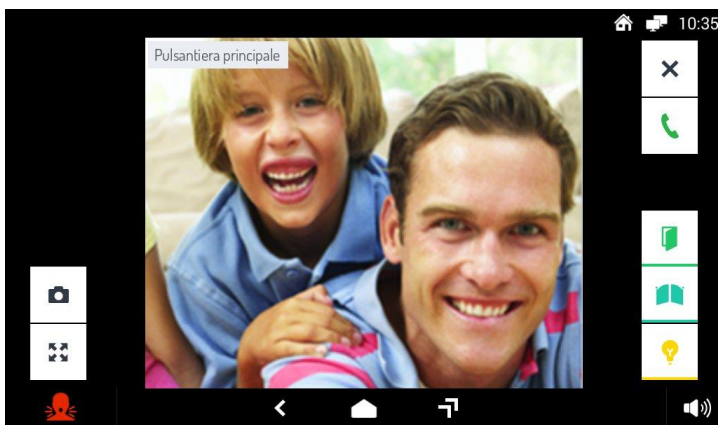

Toccando le varie icone si può:



Rifiutare la chiamata.



Rispondere alla chiamata e iniziare la conversazione in viva voce.



Aprire la porta.



Aprire il cancello dell'eventuale passo carraio.



Memorizzare un'istantanea dell'immagine esterna visualizzata sullo schermo.



Ingrandire o rimpicciolire l'immagine, cambiandone anche l'aspetto da 4:3 a 16:9.



Escludere o riattivare il microfono del videocitofono 1717/21, per evitare che chi chiama possa sentire ciò che si dice. Quando il microfono è escluso l'icona è barrata. L'icona è attiva solo dopo aver risposto.



Attivare una funzione ausiliaria, ad esempio l'accensione delle luci scala (se l'impianto Ipercom è predisposto).



Chiudere la chiamata. Lo schermo si spegne. L'icona è attiva solo dopo aver risposto.



Modificare il volume dell'audio dal posto di chiamata verso il videocitofono 1717/21 (altoparlante videocitofono).

COME ATTIVARE UN COMANDO YOKIS

Dalla Top Page premere il pulsante  per raggiungere la Domotica Yokis:

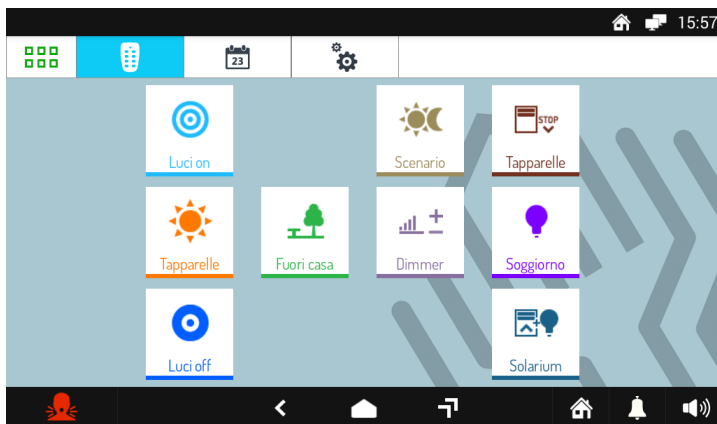

Da qui selezionare il comando o i comandi desiderati, oppure accedere alla pagina delle schedalizzazioni.

Per schedulare un comando in una o più occorrenze settimanali premere .

Nella nuova videata il pulsante **Nuova**  permette di creare una nuova schedulazione. Si apre la videata seguente nella quale è possibile impostare l'ora e i giorni di attivazione (scheduling):

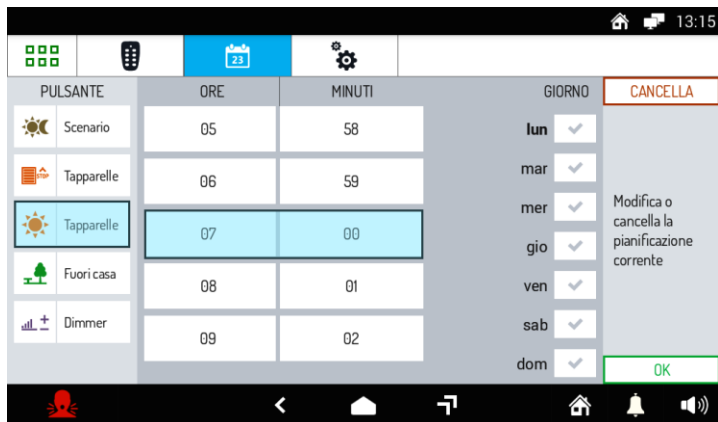

Per maggiori informazioni inquadrare il QR Code seguente con la fotocamera del proprio smartphone o tablet :



ENGLISH

FUNCTIONS

HOW TO TURN ON THE SCREEN AND ACCESS THE VARIOUS FUNCTIONS

- Tap the screen at any point, or
- Press the button (5) at the bottom right below the video door phone to display the Home Page.

The default Home Page is the video door phone application,

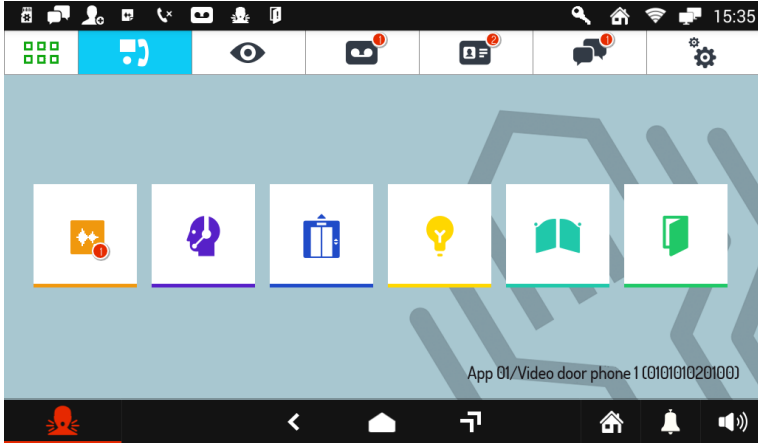

The following information is displayed in the bottom right:

- App 01:** Indicates the name of the apartment where the video door phone is present.
- Video door phone 1:** This is the name assigned to the video door phone by the installer during configuration.
- 010101020100:** Video door phone ID code.

which gives access to the following video door phone functions::



Recording short audio messages (Post-It).



Calling the switchboard.



Activate an auxiliary function, e.g. a relay to enable the lift to reach the required floor (if the lpercom system is set up appropriately).





Activating an auxiliary function, e.g. turning on the stair lights (if the lpercom system is adequately pre-set).



Opening a driveway or garage gate.



Opening the door.

To change the default application tap the icon  provided in the top left corner, to access the Top Page, then tap the Set-up icon and  finally the Home Page menu.

The other navigation icons in the top bar can be used to:



View footage from the cameras present in the system.



View recorded audio-video messages (video door phone messaging system).



Display the Phone Book and the call log.



Send text messages (Chat).



Change the audio/video screen settings and/or operation language.

The navigation icons in the bottom bar can be used to:



Return to the previous page.



Return to the Home Page.



Go to the page that lists the recently opened applications.



Send a panic alarm signal (function enabled if the Ipercom system includes a suitably configured concierge switchboard service).



Mute the call (Mute) to the video door phone for a user-settable period of time.



Change the volume of the call.



Set the following device states:
At home / Recording / Divert / Remote (only one active at a time).

HOW TO INTERPRET THE REPORTS

The bar at the top of the screen shows status information.













Micro SD Card in.



Presence of an unread text message (Chat).



New contact request.

	New Post-it not yet listened to.
	Missed Call.
	Video message not yet viewed.
	Panic Alarm sent/cancelled.
	Presence of open door
	Automatic door opening (if this feature is enabled).
	At Home / Recording / Divert / Remote / (only one active at a time).
	Active WiFi or 2nd LAN connection (only one active at a time).
	LAN connections to Ipercom network.
	Time.

HOW TO NAVIGATE BETWEEN APPLICATIONS

The various applications are accessible from the Top Page, by tapping the special icon.

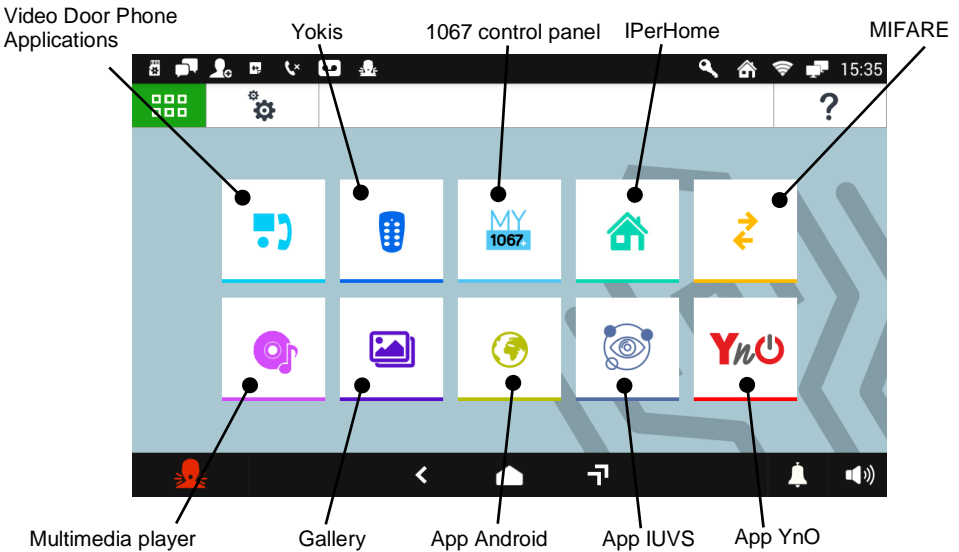

Example of Top Page

- **Video door phone:** see "HOW TO ANSWER AN EXTERNAL CALL".
- **Yokis:** see "HOW TO ACTIVATE A YOKIS CONTROL".
- **App MY1067+:** application for viewing the status of the burglar alarm 1067 present in the system.
- **IPerHome:** app for accessing and manage IPerHome home automation.
- **MIFARE:** app for allowing entrances and exits from the apartment.
- **Media player:** app for playing of audio files if the SD card is present.
- **Gallery:** app for viewing images on the video door phone display.
- **Android App:** for accessing all preloaded Android Apps and Widgets.
- **iUVS App:** for viewing images from the cameras in the system.
- **YnO App:** app for accessing and managing Yokis home automation.

For more details, download the **complete User handbook** by scanning the QR Code at the end of this section.



To return to the Home Page from any screen page, tap the icon  in the middle of the bottom bar.

HOW TO TURN OFF THE SCREEN

To turn off the screen press the button (5) of the 1717/21 video door phone or wait for the timeout set in the Configuration menu.

HOW TO ANSWER AN EXTERNAL CALL

When the video door phone Ref. 1717/21 receives an external video door phone call, it rings and the screen lights up from its default switched-off state. The caller's image will appear on the video door phone display.

If there are more than one video door phone in the apartment when a call is received, only the Master video door phone will display the caller's image. To view the caller's image on a Slave video door phone, press "**Touch to view who is calling you**" on the video door phone display.

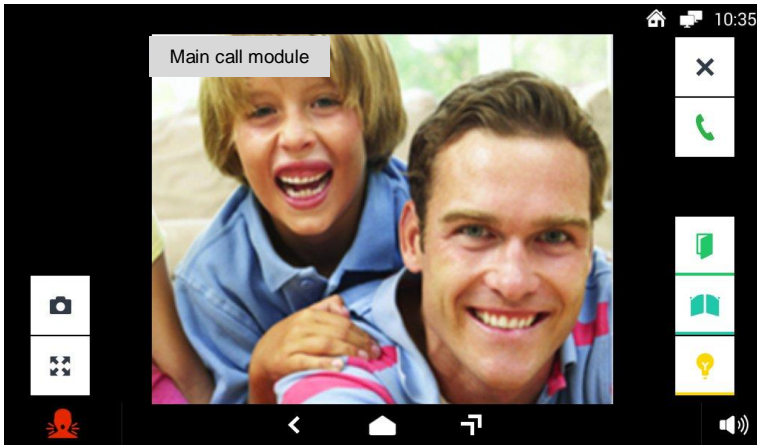

By tapping the various icons you can:



Reject the call.



Answer the call and begin a hands-free conversation.



Open the door.



Open a driveway or garage gate.



Store a snapshot of the outdoor image displayed on the screen.



Enlarge or shrink the image, also changing its format from 4:3 to 16:9.



Turn the 1717/21 video door phone microphone off and then back on, to prevent the caller hearing what you are saying. When the microphone is turned off, the corresponding icon is crossed out. The icon will only be active after the call has been answered.



Activate an auxiliary function, e.g. turning on the stair lights (if the Ipercom system is adequately pre-set).



Close the call. The screen goes off. The icon will only be active after the call has been answered.



Change the audio volume in the calling point-to-1717/21 video door phone direction (video door phone speaker).

HOW TO ACTIVATE A YOKIS CONTROL



From the Top Page press the button  to reach Yokis Home Automation:

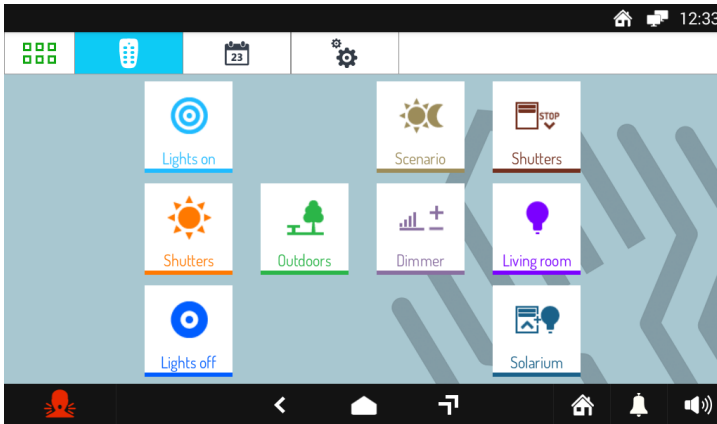

From here, select your required control or controls, or access the scheduling page.

To schedule a control for one or more weekly occurrences press .

In the new screen the button New  can be used to create a new scheduling. The next screen will open where you can set the activation times and days (scheduling):

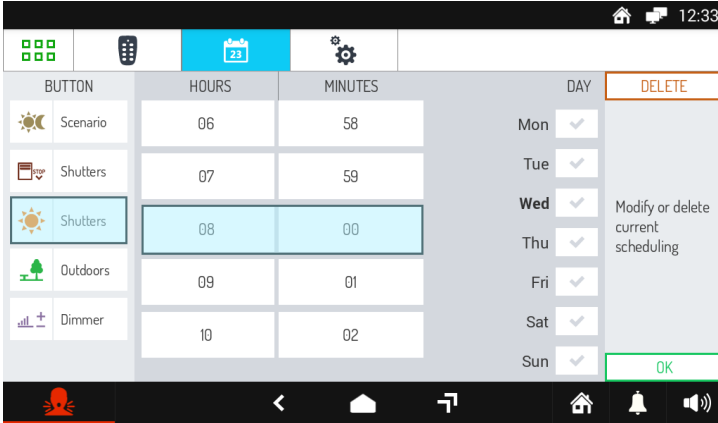

For more information scan the QR Code below with your smartphone or tablet:

FRANÇAIS

FONCTIONNEMENT

ALLUMAGE DE L'ÉCRAN ET ACCÈS AUX DIFFÉRENTES FONCTIONS

- Toucher l'écran à n'importe quel endroit ou bien
- La page d'accueil s'affiche en appuyant sur le bouton (5) en bas à droite sous le moniteur.

La Home Page par défaut correspond à l'application de Vidéophonie,

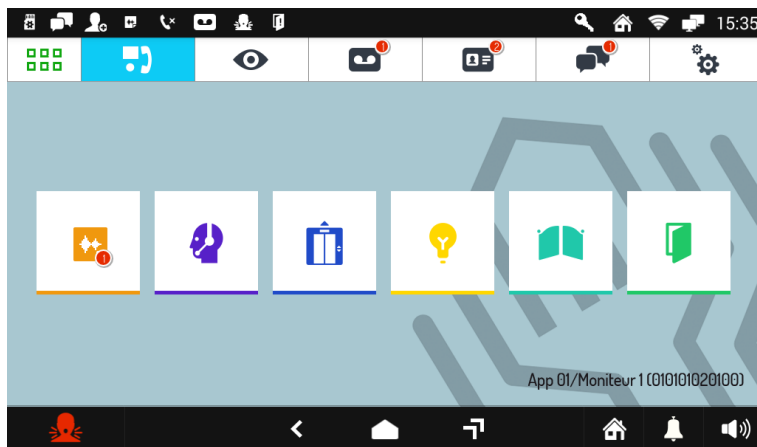

En bas à droit, il est possible d'afficher les informations suivantes:

- App 01:** Indique le nom de l'appartement où se trouve le moniteur.
Moniteur 1: Indique le nom attribué au moniteur pendant la phase de configuration.
010101020100: Code d'identification du moniteur.

Depuis laquelle il est possible d'accéder aux fonctions vidéophoniques suivantes :



Enregistrer de brefs messages audio (Post-It).



Appeler le standard.



Activer une fonction auxiliaire, par exemple l'activation d'un relais pour permettre à l'ascenseur d'atteindre l'étage souhaité (si l'installation Ipercom est dûment préparée).





Activer une fonction auxiliaire, par exemple l'allumage des lumières des escaliers (si l'installation Ipercom est prévue à cet effet).



Ouvrir la grille de l'éventuel accès voiture.



Ouvrir la porte.

Pour modifier l'application par défaut, toucher l'icône  , située en haut à gauche, qui permet d'accéder à la Top Page, puis toucher l'icône Configuration  et pour finir le menu Home Page.

Les autres icônes de navigation de la barre supérieure permettent d'effectuer les opérations suivantes :



Visualiser les images filmées par les caméras présentes sur l'installation.



Visualiser les messages audio-vidéo enregistrés (Répondeur vidéophonique).



Visualiser le Répertoire des contacts et le registre des appels.



Envoyer des messages de texte (Chat).



Modifier les réglages audio/vidéo de l'écran et/ou la langue de fonctionnement.

Les icônes de la barre inférieure permettent d'effectuer les opérations suivantes:



Revenir à la page précédente.



Aller à la Home Page.



Accéder à la page indiquant les applications récemment ouvertes.



Envoyer une notification d'alarme panique (fonction disponible à condition que sur l'installation Ipercom soit présent un standard de concierge configuré à cet effet).



Mettre l'appel du dispositif en mode silencieux (Mute) pendant une durée librement programmable.



Modifier le volume de l'appel.



Sélectionner les états suivants du dispositif :
A la maison / Répondeur / Renvoyer / Distant (les options s'excluent les unes les autres).

INTERPRÉTATION DES NOTIFICATIONS

La barre supérieure de l'écran affiche les informations d'état.

















Micro-carte SD en place.



Présence d'un message de texte (Chat) non lu.



Demande de nouveau contact.

	Présence d'un Post-it non écouté.
	Appel en absence.
	Présence d'un message vidéo non regardé.
 	Alarme panique envoyée/annulée.
	Présence porte ouverte
	Ouverture automatique de la porte (si la fonction est active).
   	A la maison / Répondeur / Renvoyer / Distant (les options s'excluent les unes les autres).
	Connexion WiFi active ou au 2 ^e réseau LAN (chaque option exclut l'autre).
	Connexions LAN au réseau Ipercom.
	Heure.

NAVIGUER D'UNE APPLICATION À L'AUTRE

Les différentes applications sont accessibles depuis la Top Page en touchant l'icône correspondante.

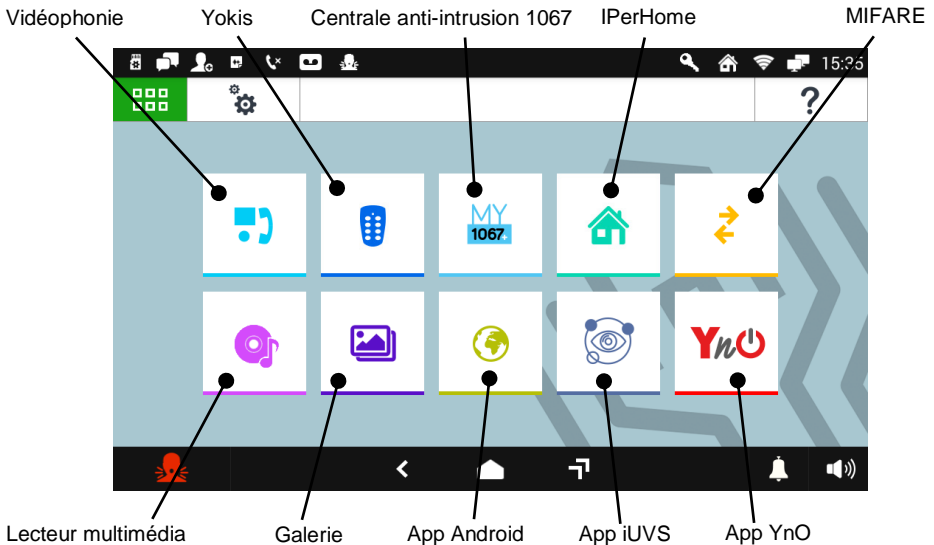

Exemple de Top Page

- **Vidéophonie** : se reporter au chapitre « RÉPONDRE À UNE APPEL EXTÉRIEUR ».
- **Yokis** : se reporter au chapitre « ACTIVATION D'UNE COMMANDE YOKIS ».
- **App MY1067+** : application qui permet d'afficher l'état de la centrale anti-intrusion 1067 présente sur l'installation.
- **IPerHome** : application qui permet d'accéder et de gérer la domotique IPerHome.
- **MIFARE** : application qui permet d'enregistrer les entrées et les sorties de l'appartement.
- **Lecteur multimédia** : application qui permet de reproduire les fichiers audio si la carte SD est présente.
- **Galerie** : application qui permet d'afficher les images sur l'écran du moniteur.
- **Android App** : permet d'accéder à toutes les applications et widgets Android préchargés.
- **App iUVS** : permet d'afficher les images en provenance des caméras présentes sur l'installation.
- **App YnO** : application qui permet de gérer la domotique de Yokis.

Pour plus de détails, télécharger le **Manuel utilisateur complet** suite à la lecture du code QR présent à la fin de cette section.



Pour revenir à la Home Page depuis toute page visualisée, toucher l'icône  située au centre de la barre inférieure.

ÉTEINDRE L'ÉCRAN

Pour éteindre l'écran, appuyer sur la touche (5) du moniteur 1717/21 ou attendre que la durée de timeout réglée dans le menu Configuration se soit écoulée.

REPONDRE A UNE APPEL EXTERIEUR

Lorsque le moniteur Réf. 1717/21 reçoit un appel vidéophonique extérieur, il sonne et allume l'écran (qui est normalement éteint). Le moniteur affichera l'image de l'appelant à l'écran.

En présence de plusieurs moniteurs dans l'appartement, seul le moniteur Maître affichera l'image de l'appelant lors de la réception d'un appel.

Pour afficher l'image de l'appelant sur un moniteur Esclave, appuyer sur la commande « **Toucher ici pour savoir qui est en train d'appeler** », qui apparaît à l'écran du moniteur.

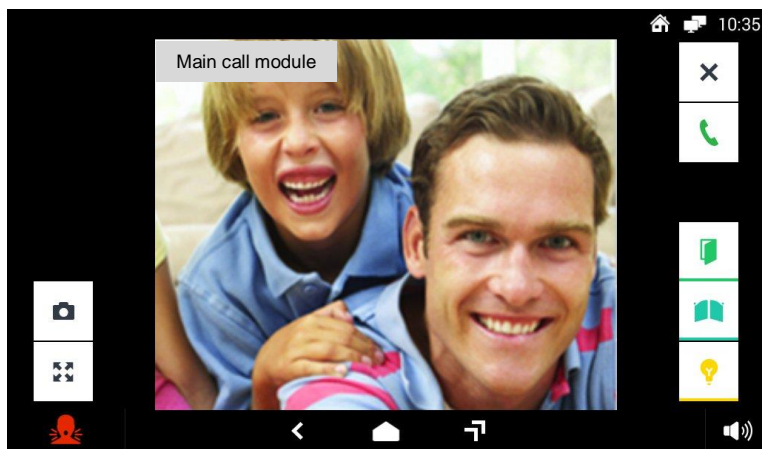

En touchant les icônes correspondantes, il est possible de:

 Refuser l'appel.

 Répondre à l'appel et entamer la conservation en mode mains libres.



Ouvrir la porte.



Ouvrir la grille de l'éventuel accès voiture.



Mémoriser une capture de l'image visualisée sur l'écran.



Agrandir et réduire l'image, en en modifiant également le format (de 4:3 à 16:9).



Désactiver ou réactiver le micro du moniteur 1717/21 pour éviter que l'appelant ne puisse entendre ce qui est dit. Quand le micro est désactivé, l'icône est barrée. L'icône n'est active qu'après avoir répondu.



Activer une fonction auxiliaire, par exemple l'allumage des lumières des escaliers (si l'installation Ipercom est prévue à cet effet).



Mettre fin à l'appel. L'écran s'éteint. L'icône n'est active qu'après avoir répondu.



Modifier le volume audio, du poste d'appel au moniteur 1717/21 (haut-parleur moniteur).

ACTIVATION D'UNE COMMANDE YOKIS



Depuis la Top Page, appuyer sur le bouton pour accéder à la Domotique Yokis:

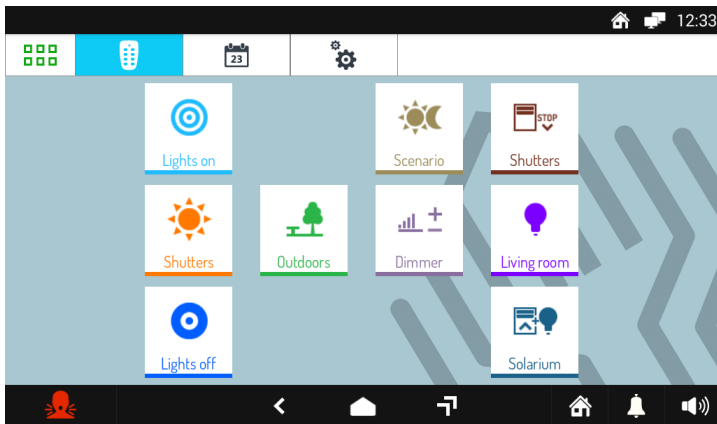

Ensuite, sélectionner la ou les commandes voulues ou accéder à la page des programmations.

Pour programmer une commande en une ou plusieurs occasions hebdomadaires, appuyer sur



New +

Sur la page qui s'affiche, le bouton **New** permet de créer une nouvelle programmation. La page suivante s'affiche qui permet de régler l'heure et les jours d'activation (programmation):

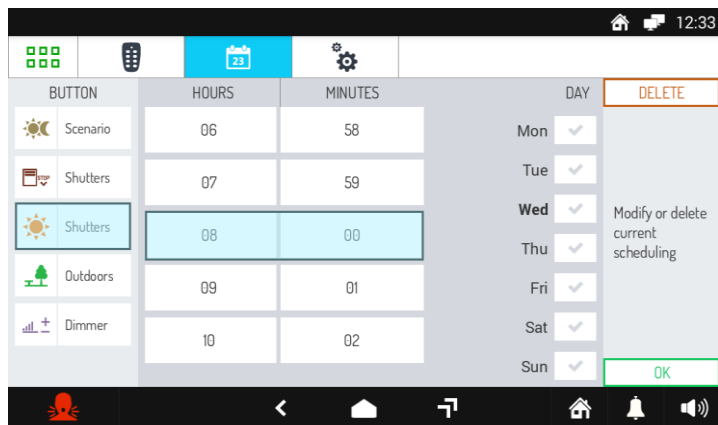

Pour plus d'information, photographier le code QR suivant à l'aide de l'appareil-photo de son propre smartphone ou tablette:



ESPAÑOL

FUNCIONES

CÓMO ENCENDER LA PANTALLA Y ACCEDER A LAS DIFERENTES FUNCIONES

- Toque la pantalla en cualquier lugar, o
- Accionar el pulsador (5) de abajo, a la derecha, debajo del videointerfono, que hará que aparezca la Página Principal.

La página de inicio predeterminada es la aplicación del Videocitófono,

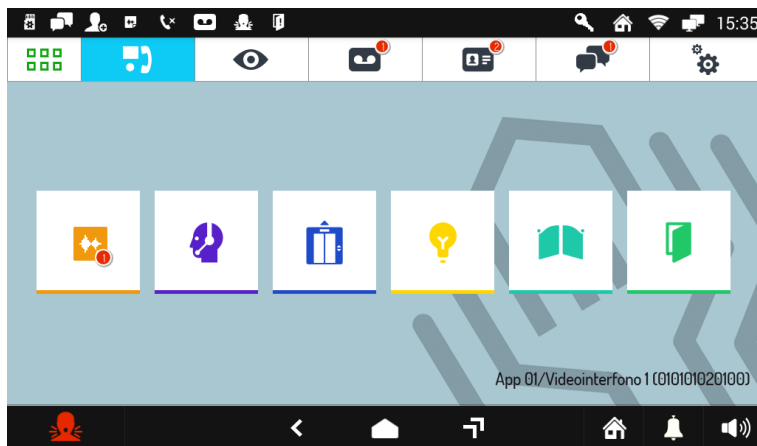

Abajo, a la derecha, es posible ver la siguiente información.

App 01: Indica el nombre de la vivienda donde se ubica el videointerfono.

Videointerfono 1: Indica el nombre asignado al videointerfono en la fase de configuración.

010101020100: Código de identificación del videointerfono.

Desde la cual se pueden acceder a las siguientes funciones del videocitófono:



Grabar mensajes de audio cortos (Post-It).



Llamar al conmutador.



Activar una función auxiliar, por ejemplo, la activación de un relé para permitir habilitar la llegada del ascensor a la planta deseada (cuando el sistema Ipercom está debidamente preparado).



Activar una función auxiliar, por ejemplo encender las luces (si el sistema Ipercom está predispuerto).



Abrir la puerta de cualquier entrada.



Abrir la puerta.

Para cambiar la aplicación predeterminada pulse el icono,  situado en la parte superior izquierda, que le da acceso a la página de la parte superior, a continuación, pulse el icono de configuración

 y por último el menú de la página de inicio.

Los otros iconos en la barra de navegación en la parte superior le permiten:



Ver las imágenes que se filman en las cámaras de vídeo presentes en el sistema.



Ver los mensajes grabados de audio y video (portería).



Mostrar la libreta de contactos y el historial de llamadas.



Enviar mensajes de texto (Chat).



Cambiar la configuración de audio y video del videointerfono y/o idioma de funcionamiento.

Los iconos de barra inferior le permiten:



Volver a la página anterior.



Volver a la página de inicio.



Ir a la página que enumera las aplicaciones recientemente abiertas.



Enviar una alarma de pánico (puede funcionar si en el sistema Ipercom está presente un conmutador de portería correctamente configurado).



Silenciar la llamada (Mute) del videointerfono por un período de tiempo que se puede establecer como lo desee.



Cambiar el volumen de la llamada.



Configurar los siguientes estados del dispositivo:
En casa / Contestador / Reenviar / A distancia (alternativas entre sí).

CÓMO INTERPRETAR LAS ALARMAS

La barra superior de la pantalla muestra la información del estado.













Tarjeta micro SD insertada.



Mensaje de texto (Chat) no leído.



Solicitud de un nuevo contacto.

	Post-it no escuchado.
	Llamada pérdida.
	Mensaje de vídeo no visto.
	Alarma de pánico enviada/cancelada.
	Presencia de puerta abierta
	Apertura de puerta automática (si la función está habilitada).
	En casa / Contestador / Reenviar / A distancia (alternativas entre sí).
	Conexión WiFi activa o la LAN 2 (alternativas entre sí).
	Conexión LAN a la red Ipercom.
	Hora.

CÓMO NAVEGAR ENTRE LAS APLICACIONES

Se pueden acceder a las diversas aplicaciones desde la página de la parte superior, pulsando el icono.

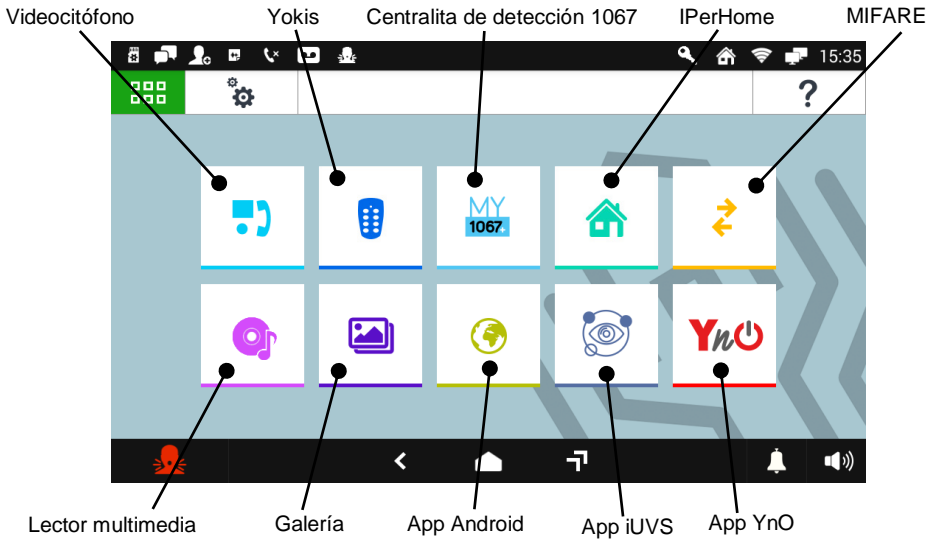

Ejemplo de página superior

- **Videointerfonía:** consultar el capítulo “CÓMO CONTESTAR UNA LLAMADA EXTERNA”.
- **Yokis:** consultar el capítulo “CÓMO ACTIVAR UN COMANDO YOKIS”.
- **App MY1067+:** aplicación que permite ver el estado de la centralita de detección de intrusión 1067 presente en el sistema.
- **IPerHome:** aplicación que permite acceder y gestionar la domótica IPerHome.
- **MIFARE:** aplicación que permite registrar las entradas y las salidas del apartamento.
- **Lector multimedia:** aplicación que permite la reproducción de archivos de audio si está presente la tarjeta SD.
- **Galería:** aplicación que permite ver las imágenes en la pantalla del videointerfono.
- **App Android:** permite acceder a todas las Aplicaciones y Widgets Android precargados.
- **App iUVS:** permite ver las imágenes que llegan de las cámaras presentes en el sistema.
- **App Yno:** aplicación que permite gestionar la domótica Yokis.

Para mayor información descargar el **Manual del usuario completo** escaneando el Código QR presente al final de la sección.



Para volver a la página de inicio desde cualquier página que visualice pulse el icono de correspondencia en el centro de la barra inferior.

CÓMO APAGAR LA PANTALLA

Para apagar la pantalla pulse el botón (5) del videointerfono 1717/21 o espere el tiempo de espera establecido en el menú de configuración.

CÓMO CONTESTAR UNA LLAMADA EXTERNA

Cuando el videointerfono Ref. 1717/21 recibe una llamada videointerfónica externa, suena y enciende la pantalla, que normalmente está apagada. El videointerfono muestra en la pantalla la imagen de la persona que llama.

Si en el apartamento hay varios videointerfonos, cuando se recibe una llamada solo el videointerfono Master muestra la imagen de la persona que llama. Para ver la imagen del que llama en un videointerfono Slave, pulsar el mensaje “**Toque aquí para ver quién le está llamando**” que aparece en la pantalla del videointerfono.

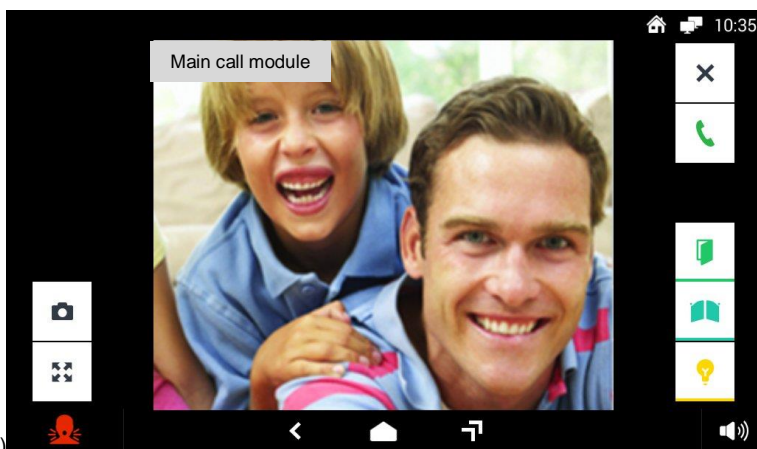

Al pulsar los iconos se puede:

 Rechazar llamada.



Responder a la llamada y hablar en altavoz.



Abrir la puerta.



Abrir la puerta de cualquier entrada.



Guardar una instantánea de la imagen externa que se muestra en la pantalla.



Ampliar o reducir la imagen, cambiando el aspecto de 4:3 a 16:9.



Silenciar o activar el micrófono del videointerfono 1717/21, para evitar que las personas que llamen puedan escuchar lo que se dice. Cuando el micrófono está silenciado, el icono se tacha. El icono se activa solo después de responder.



Activar una función auxiliar, por ejemplo encender las luces (si el sistema Ipercom está predispuesto).



Rechazar la llamada. La pantalla se apaga. El icono se activa solo después de responder.



Cambiar el volumen del audio del puesto de llamada al videointerfono 1717/21 (altavoz del videointerfono).

CÓMO ACTIVAR UN COMANDO YOKIS



Desde la página de la parte superior pulse la tecla  para llegar a la domótica Yokis:

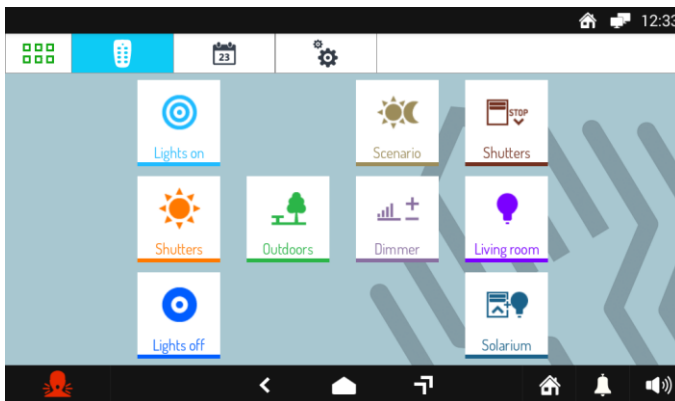

Desde aquí, seleccione el comando o comandos deseados, o ir a la página de horarios.

Para programar un comando en uno o más eventos semanales presionar  .

New 

En la nueva pantalla la tecla **New**  permite crear una nueva programación. Si abre la siguiente pantalla, en esta es posible configurar la hora y los días de activación (programación):

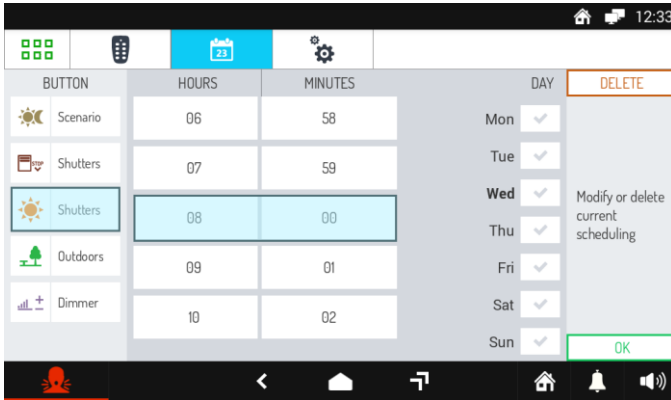

Para mayor información vea el siguiente código QR con la cámara de su smartphone o tablet:



DEUTSCH

FUNKTIONEN

EINSCHALTEN DES BILDSCHIRMS UND ZUGRIFF AUF DIE VERSCHIEDENEN FUNKTIONEN

- Tippen Sie auf einen beliebigen Punkt im Bildschirm oder
- Betätigen Sie die Taste (5) unten rechts unter der Videosprechanlage, die die Home Page aufruft.

Die Standard-Homepage ist die Videosprechanlagen-Anwendung,

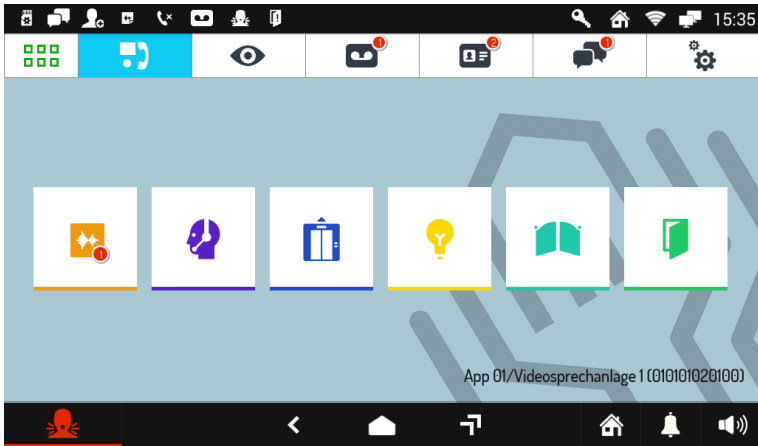

Unten links können die folgenden Informationen eingeblendet recht:

- App 01:** Zeigt den Namen der Wohnung an, in der sich das Videosprechanlage befindet
- Videosprechanlage 1:** Gibt den der Videosprechanlage während der Konfiguration zugewiesenen Namen an.
- 010101020100:** Identifizierungscode der Videosprechanlage.

von der aus auf die folgenden Videosprechfunktionen zugegriffen werden kann:



Aufzeichnung kurzer Audionachrichten (Post-It)



Ruf der Zentrale



Aktivieren Sie eine Hilfsfunktion, zum Beispiel die Aktivierung eines Relais, um die Aktivierung des Fahrstuhls zum Erreichen der gewünschten Etage zu ermöglichen (bei Ipercom-Anlagen entsprechend ausgelegt).





Aktivierung einer Hilfsfunktion, beispielsweise des Einschaltens der Treppenbeleuchtung (falls die Ipercom-Anlage vorgesehen ist)



Toröffnung einer eventuellen Toreinfahrt



Türöffnung

Zum Ändern der Standardanwendung das links oben positionierte Symbol  antippen, um Zugriff auf die Startseite zu erhalten. Dann das Konfigurationssymbol  und schließlich das Homepage-Menü antippen.

Die anderen Navigationssymbole der oberen Leiste ermöglichen Folgendes:



Anzeigen der von der zur Anlage gehörigen Kameras aufgenommenen Bilder.



Anzeigen von aufgezeichneten Audio-/Videonachrichten (Videosprechanlagebeantworter).



Anzeige der Kontaktliste und Rufaufzeichnung.



Senden von Textnachrichten (Chat).



Ändern der Audio-/Videoeinstellungen des videosprechanlage und/oder Betriebssystemsprache.

Die Symbole der oberen Leiste ermöglichen Folgendes:



Rückkehr zur vorherigen Seite.



Rückkehr zur Homepage.



Zugriff auf die Seite mit der Auflistung der zuletzt aufgerufenen Anwendungen.



Senden einer Panikalarm-Nachricht (Funktion möglich, falls die Ipercom-Anlage mit einer zweckmäßig konfigurierten Pfortner-Zentrale ausgestattet ist).



Stummschalten des Anrufs (Mute) auf dem videosprechanlage für einen nach Belieben einstellbaren Zeitraum.



Ändern der Ruflautstärke.



Einstellung der folgenden Gerätestatus:
Zuhause / Aufzeichnung / Erneut senden / Fern (alternativ zueinander).

RICHTIGE DEUTUNG DER NACHRICHTEN

Die obere Leiste des Bildschirms zeigt die Statusinformationen.



Mikro-SD-Karte eingesteckt.



Ungelesene Textnachricht (Chat) vorhanden.



Anforderung eines neuen Kontakts.



Ungehörtes Post-It vorhanden.



Entgangener Anruf.



Ungelesene Videonachricht vorhanden.



Panikalarm gesendet/aufgehoben.



Geöffnete Tür vorhanden



Automatische Türöffnung (falls die Funktion aktiviert ist).



Zuhause / Aufzeichnung / Erneut senden / Fern (alternativ zueinander).



WiFi-Verbindung aktiv oder zweite 2 LAN (alternativ zueinander).



LAN-Verbindungen zum Ipercom-Netzwerk.



Uhrzeit.

WECHSELN ZWISCHEN DEN ANWENDUNGEN

Die verschiedenen Anwendungen sind über die Startseite durch Antippen des entsprechenden Symbols erreichbar.

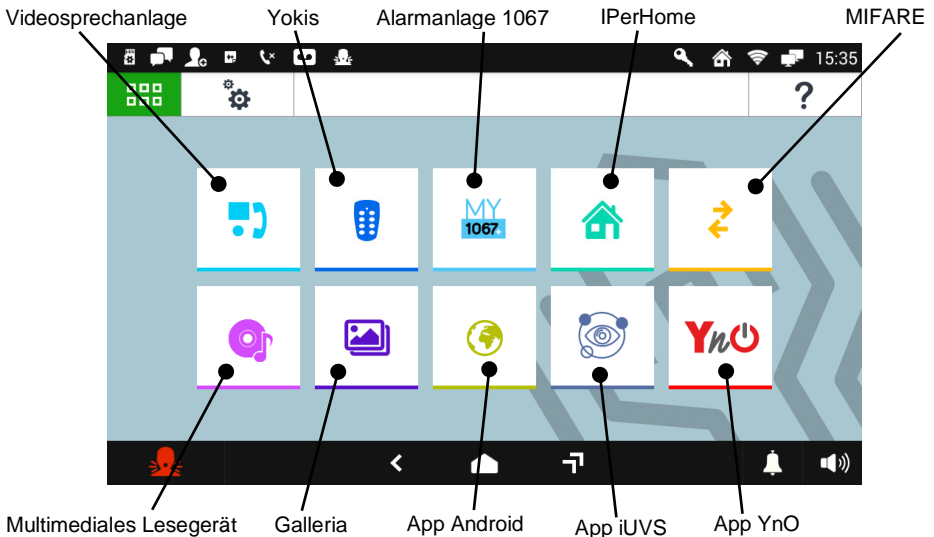

Beispiel einer Startseite

- **Videolanlage:** siehe Kapitel " ANNAHME EINES EXTERNEN ANRUFES ".
- **Yokis:** siehe Kapitel " AKTIVIERUNG EINES YOKIS-BEFEHLS".
- **App MY1067+:** Applikation, die das Einblenden des Status der Alarmanlage 1067 in der Anlage gestattet.
- **IPerHome:** Applikation, die den Zugang zur Haustechnik IPerHome und ihre Verwaltung gestattet.
- **MIFARE:** Applikation, die das Aufzeichnen der Ein- und Austritte aus der Wohnung gestattet.
- **Multimediales Lesegerät:** Applikation, die die Wiedergabe von Audiodateien gestattet, wenn die SD-Karte vorhanden ist.
- **Galleria:** Applikation, die das Einblenden der Bilder auf dem Display der Videolanlage gestattet.
- **App Android:** gestattet den Zugriff auf alle bereits geladenen Apps und Widgets von Android.
- **App iUVS:** gestattet das Einblenden der von den in der Anlage vorhandenen Kameras stammenden Bilder.
- **App YnO:** Applikation, die die Verwaltung der Haustechnik von Yokis gestattet.

Wegen weiteren Einzelheiten laden Sie die **ungekürzte Bedienungsanleitung** herunter, indem Sie den am Ende des Abschnitts angegebenen QR-Code einscannen.

Für die Rückkehr zur Homepage von jeder beliebig angezeigten Seite das in der Mitte der unteren Leiste befindliche Symbol  antippen.

BILDSCHIRM AUSSCHALTEN

Zum Ausschalten des Bildschirms die Taste (5) des videosprechanlage 1717/21 drücken oder den Ablauf der im Konfigurationsmenü eingestellten Timeout-Zeit abwarten.

ANNAHME EINES EXTERNEN ANRUFES

Wenn auf der Videosprechanlage BN 1717/21 ein externer Anruf eingeht, ertönt der Klingelton und der normalerweise ausgeschaltete Bildschirm schaltet sich ein. Auf dem Bildschirm der Videosprechanlage erscheint das Bild des Anrufers. Sind in der Wohnung mehrere Videosprechanlagen vorhanden, erscheint beim Eingang eines Anrufs nur auf der Master-Videosprechanlage das Bild des Anrufers. Um das Bild des Anrufers auf einer Slave-Videolanlage anzuzeigen, auf den Satz „**Berühren um den Anrufenden zu sehen**“, der im Display der Videosprechanlage erscheint.

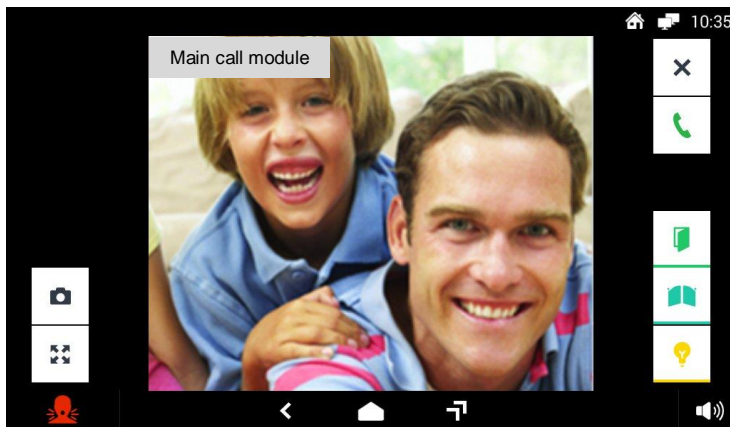

Durch Antippen der verschiedenen Symbole kann man Folgendes:



Einen Anruf ablehnen.



Einen Anruf annehmen und das Gespräch im Freisprechmodus beginnen.



Die Tür öffnen.



Das Tor einer eventuellen Toreinfahrt öffnen.



Einen Schnappschuss des auf dem Bildschirm angezeigten externen Bildes speichern.



Das Bild vergrößern oder verkleinern und dessen Aussehen ebenfalls von 4:3 auf 16:9 ändern.



Das Mikrofon des Videosprechanlage 1717/21 aus- bzw. wieder einzuschalten, um zu verhindern, dass der Anrufer mithören kann. Bei ausgeschaltetem Mikrofon ist das Symbol durchgestrichen. Das Symbol ist erst aktiv, nachdem geantwortet wird.



Eine Hilfsfunktion aktivieren, beispielsweise das Einschalten der Treppenbeleuchtung (falls die Ipercom-Anlage vorgesehen ist)



Den Anruf beenden. Der Bildschirm schaltet sich aus. Das Symbol ist erst aktiv, nachdem geantwortet wird.



Die Lautstärke von der Rufstelle zum Videosprechanlage 1717/21 ändern (Lautsprecher videosprechanlage).

AKTIVIERUNG EINES YOKIS-BEFEHLS



Auf der Startseite die Taste drücken, um zur Yokis-Domotik zu gelangen:

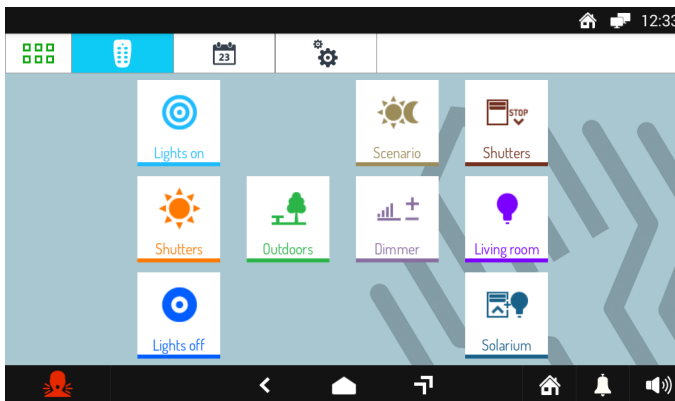

Von dort aus den gewünschten Befehl bzw. die gewünschten Befehle erteilen oder auf die Seite der Planungen zugreifen.



Um einen bestimmten Befehl einmal oder mehrmals pro Woche einzuplanen, die Taste drücken.

New +

In der neuen Bildschirmansicht kann über die Taste **New +** eine neue Planung erstellt werden. Es öffnet sich die folgende Bildschirmansicht, in der man die Uhrzeit und die Tage, die für Aktivierung vorgesehen sind, einstellen kann (scheduling).

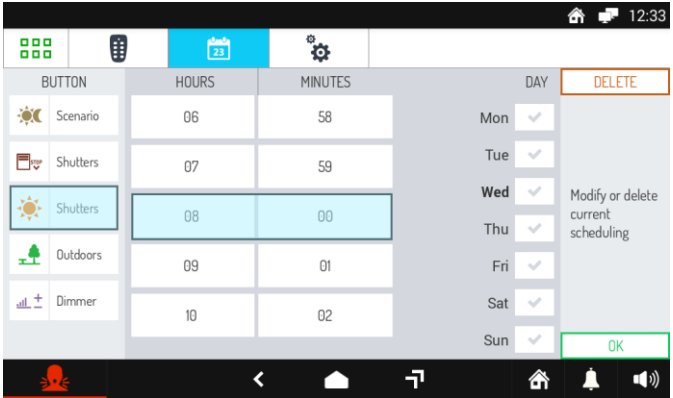

Für nähere Informationen nehmen Sie bitte den folgenden QR-Code mit der Kamera Ihres Smartphones oder Tablets auf:



NEDERLANDS

FUNCTIES

TOEGANG TOT HET SCHERM EN TOT DE VERSCHILLENDE FUNCTIES

- Raak het scherm op een willekeurig punt aan, of
- Druk op de knop (5) rechts onder de videointercom om de Home-pagina te openen.

De standaard Home Page is de beeldintercom-toepassing,

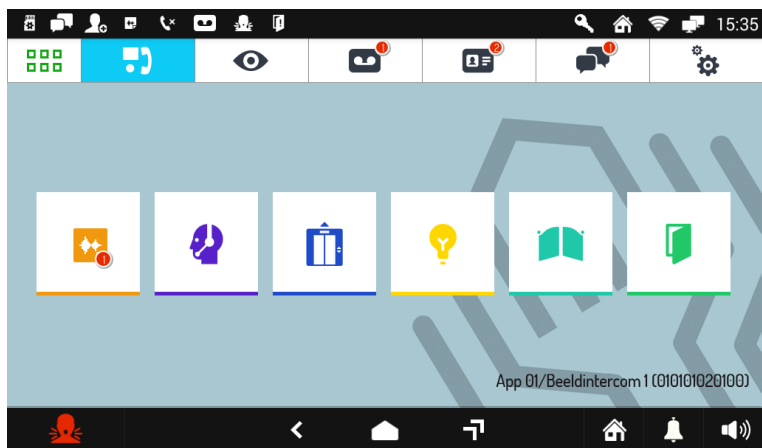

Onderaan rechtsaf kunt u de volgende informatie weergeven

- App 01:** Geeft de naam van het appartement aan waar de Beeldintercom aanwezig is.
- Beeldintercom 1:** Signaleert de naam die is toegewezen aan de beeldintercom tijdens de configuratie.
- 010101020100:** Identificatiecode van de beeldintercom.

Van waaruit u toegang heeft tot de volgende beeldintercom-functies:



Opnemen van korte audioberichten (Post-it).



De centrale oproepen.



Een hulpfunctie activeren, bijvoorbeeld een relais om de lift naar de gewenste verdieping te sturen (als het Ipercom-systeem hiervoor is uitgerust).





Een extra functie activeren, bijvoorbeeld het inschakelen van de trapverlichting (als het Ipercom-systeem hiertoe is uitgerust).



Het openen van het hek van de eventuele uitrit.



De deur openen.

Om de standaard toepassing te wijzigen, raakt u het symbool  linksboven aan, dat toegang geeft tot de Top Page, daarna raakt u het symbool Configuratie  aan en tenslotte het Home page-menu.

Met de overige navigatiesymbolen in de bovenste balk kunt u:



De beelden weergeven die door de camera's van het systeem zijn opgenomen.



De geregistreerde audio-videoberichten weergeven (Video-voicemail).



De lijst met contactpersonen en de oproepgeschiedenis weergeven.



Tekstberichten sturen (chatten).



De audio/video-instellingen van de IP Beeldintercom wijzigen en/of de interfacetaal.

Met de symbolen in de onderste balk, kunt u:



Terugkeren naar de vorige pagina.



Terugkeren naar de Home Page.



Naar de pagina gaan met de lijst met onlangs geopende toepassingen.



Een signalering voor paniekalarm versturen (functie alleen mogelijk als in het lpercom-systeem een correct geconfigureerde portiercentrale aanwezig is).



De oproep op de IP Beeldintercom op stil (Mute) zetten voor een gewenste, instelbare periode.



Het oproepvolume wijzigen.



De volgende statussen van het toestel instellen:
Thuis / Video Voicemail / Opnieuw verzenden / Doorschakelen (elkaar afwisselend).

DE SIGNALERINGEN INTERPRETEREN

De bovenste balk in het scherm toont de statusinformatie.



Micro SD-kaart ingestoken.



Er is een ongelezen tekstbericht (chat).



Nieuw contactpersoonverzoek.



Er is een onbeluisterd audiobericht.



Oproep gemist.



Er is een nog niet bekeken videobericht.



Paniekalarm verzonden/geannuleerd.



Open deur aanwezig



Automatische deuropening (als de functie actief is).



Thuis / Video Voicemail / Opnieuw verzenden / Doorschakelen (elkaar afwisselend).



Actieve WiFi-verbinding of naar de 2^e LAN (elkaar afwisselend).



LAN-verbinding met het Ipercom-netwerk.



Tijd.

DOOR DE TOEPASSINGEN NAVIGEREN

De verschillende toepassingen zijn toegankelijk via de Top Page, door het betreffende symbool aan te raken.

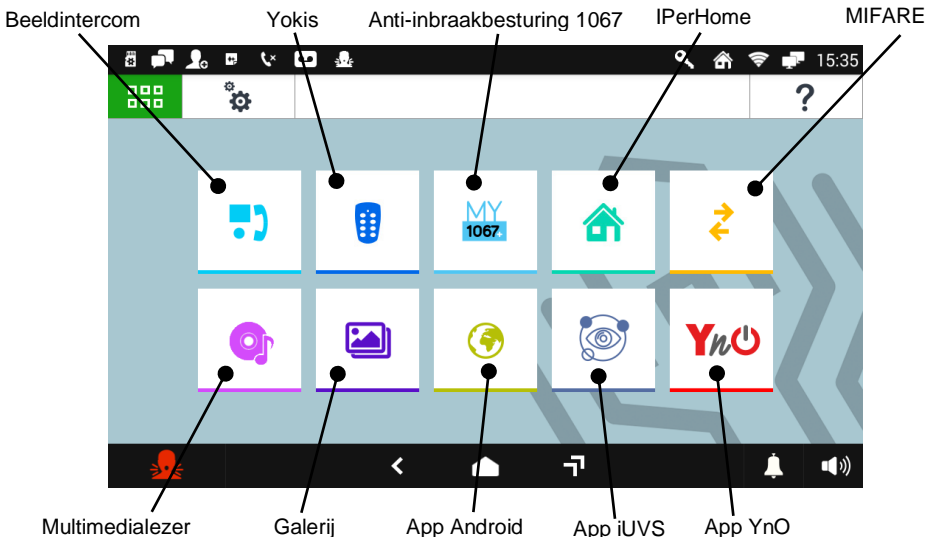

Voorbeeld van Top Page

- **Videointercomfunctie:** zie het hoofdstuk “EEN OPROEP AFKOMSTIG UIT HET BUITENLAND BEANTWOORDEN”.
- **Yokis:** zie het hoofdstuk “EEN YOKIS-COMMANDO ACTIVEREN”.
- **App MY1067+:** applicatie om de status van de anti-inbraakbesturing 1067 in het systeem te bekijken.
- **IPerHome:** applicatie om de domotica IPerHome te openen en te beheren.
- **MIFARE:** applicatie om het betreden en verlaten van het appartement te registreren.
- **Multimedialezer:** applicatie om geluidsbestanden af te spelen als een SD-kaart aanwezig is.
- **Galerij:** applicatie om afbeeldingen te bekijken op het display van de videointercom.
- **App Android:** om alle reeds ingeladen Android App's en Widgets te gebruiken.
- **App iUVS:** om afbeeldingen te bekijken die afkomstig zijn van de camera's in het systeem.
- **App YnO:** applicatie om de domotica van Yokis te beheren.

Download voor meer details de **volledige Gebruiksaanwijzing** met de QR-code aan het einde van dit tekstgedeelte.



Om vanuit een weergegeven pagina terug te keren naar de Home Page drukt u op het symbool in het midden van de onderste balk.

HET SCHERM UITSCHAKELEN

Om het scherm uit te schakelen, drukt op de toets (5) van de IP Beeldintercom 1717/21 of wacht u op de in het configuratiemenu ingestelde timeout.

EEN OPROEP AFKOMSTIG UIT HET BUITENLAND BEANTWOORDEN

Als de beeldintercom Sch. 1717/21 een externe beeldintercomoproep ontvangt, gaat de bel en wordt het scherm dat normaalgesproken uitgeschakeld is, ingeschakeld. Op het display van de beeldintercom verschijnt het beeld van de oproeper.

Als in de woning meerdere beeldintercomtoestellen zijn, verschijnt alleen op het Master-toestel het beeld van de oproeper. Om het beeld van de oproeper ook op een Slave-toestel te laten verschijnen, drukt u op de melding “**Raak scherma aan om te zien wie u belt**” die op het display van de beeldintercom verschijnt.

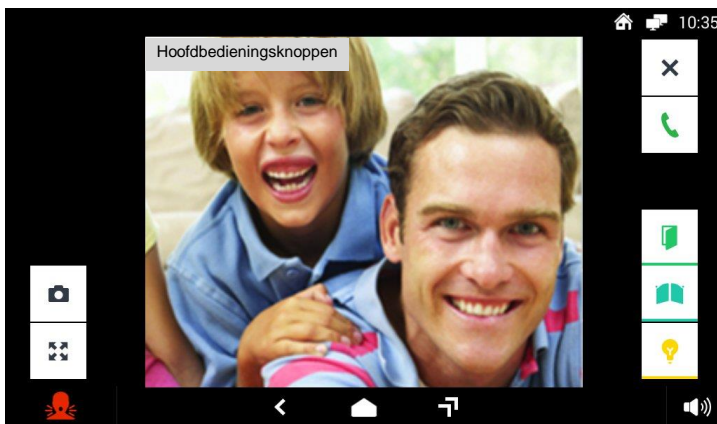

Door de verschillende symbolen aan te raken, kunt u:



De oproep weigeren.



De oproep beantwoorden en een handsfree gesprek beginnen.



De deur openen.



Het hek van de eventuele uitrit openen.



Een momentopname maken van het externe beeld dat op het scherm wordt getoond.



Het beeld vergroten of verkleinen en de weergave veranderen van 4:3 tot 16:9.



De microfoon van de IP Beeldintercom 1717/21 uitschakelen en opnieuw activeren, om te voorkomen dat degene die belt hoort wat er gezegd wordt. Als de microfoon gedeactiveerd is, staat er een streep door het symbool. Het symbool is alleen actief nadat u heeft opgenomen.



Een extra functie activeren, bijvoorbeeld het inschakelen van de trapverlichting (als het lpercom-systeem hiertoe is uitgerust).



De oproep afsluiten. Het scherm schakelt uit. Het symbool is alleen actief nadat u heeft opgenomen.



Het audiovolume wijzigen vanaf de plaats van de oproep naar de IP Beeldintercom 1717/21 (Beeldintercom spreker).

EEN YOKIS-COMMANDO ACTIVEREN



Vanaf de Top Page drukt u op de toets voor toegang tot de Yokis huisautomatisering:

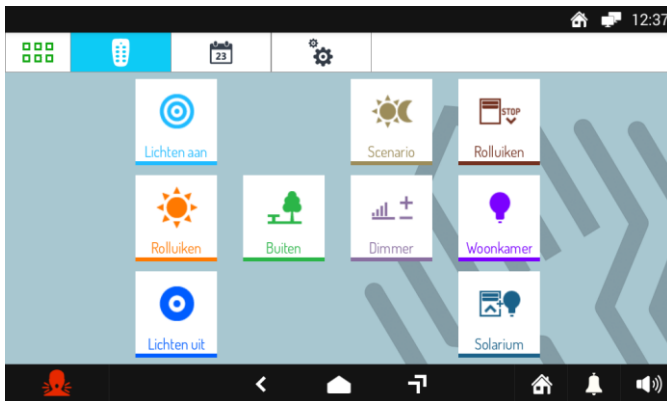

Hier kunt de gewenste commando of commando's selecteren of kunt naar de pagina gaan met de planningen.



Om een commando één of meerdere keren per week in te plannen, drukt u op .

Nieuwe 

In het nieuwe scherm kan met de toets  een nieuwe planning worden aangemaakt. Het volgende scherm wordt geopend waarin het mogelijk is de tijd en de dag van activering in te stellen (planning):



Voor meer informatie scant u de QR-code met de fotocamera van uw smartphone of tablet:



DS1717-073A

URMET S.p.A.
10154 TORINO (ITALY)
VIA BOLOGNA 188/C
Telef. +39. 011.24.00.000 (RIC.AUT.)
Fax +39. 011.24.00.300 - 323

urmet

LBT20902

Area tecnica
servizio clienti +39. 011.23.39.810
<http://www.urmet.com>
e-mail: info@urmet.com