

# urmet

| 2 |  
voice

Mod.  
1760

DS1760-044

LBT21225

**VIDEOCITOFONO 2VOICE VIVAVOCE WiFi**  
**2VOICE HANDS-FREE WiFi VIDEO DOOR PHONE**  
**MONITEUR 2VOICE MAIN-LIBRES WIFI**  
**VIDEOINTERFONO 2VOICE MANOS LIBRES WIFI**  
**VIDEOSPRECHANLAGE 2VOICE VIVAVOCE WIFI**  
**VIDEO-INTERCOM 2VOICE HANDSFREE Wifi**

works  
with



**Sch./Ref. 1760/15**

(nero / black / noire / negro / schwarz / zwart)

**Sch./Ref. 1760/16**

(bianco / white / blanc / blanco / weiß / wit)

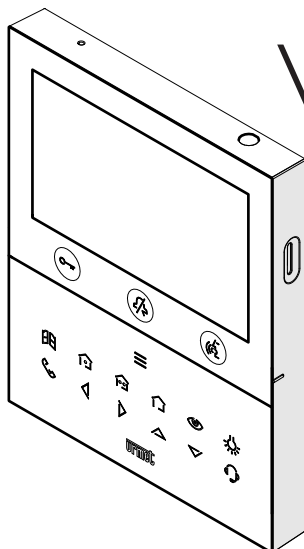

**VOG 5W**



**GUIDA RAPIDA PER L'UTILIZZO**  
**QUICK GUIDE FOR USE**  
**GUIDE RAPIDE D'UTILISATION**  
**GUÍA RAPIDA DE USO**  
**SCHNELLANLEITUNG ZUM GEBRAUCH**  
**SNELLE GIDS VOOR HET BEBRUIK**

# ITALIANO

## 1. DESCRIZIONE GENERALE

I videocitofoni VOG<sup>SM</sup> Sch. 1760/15 e Sch. 1760/16 sono dedicati all'utilizzo in impianti videocitofonici del sistema 2Voice.

## 2. DESCRIZIONE DEI COMPONENTI E CARATTERISTICHE

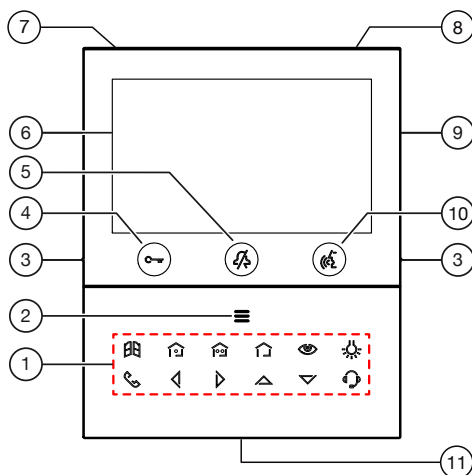

### 1. Tasti funzione:

- : tasto apriporta passo carraio
- : tasto attivazione comando Yokis 1
- : tasto attivazione comando Yokis 2
- : tasto menu pulsanti Yokis
- : tasto autoinserzione / palleggiamento video
- : tasto funzione speciale
- : tasto chiamata intercomunicante
- : tasto freccia scorrimento verso sinistra
- : tasto freccia scorrimento verso destra
- : tasto freccia scorrimento verso l'alto
- : tasto freccia scorrimento verso il basso
- : tasto chiamata al centralino

2. Tasto per l'attivazione delle funzioni secondarie / accensione del display (con led verde di retroilluminazione)

3. Tacche in rilievo per non vedenti

4. Tasto apriporta pedonale (con led verde / rosso di retroilluminazione)



5. Tasto funzione "MUTE" (con led rosso di retroilluminazione)

6. Display 5"









7. Microfono













8. Sensore IR per comandi gestuali

9. Alloggiamento per micro SD  
 10. Tasto attivazione/disattivazione fonia  (con led verde di retroilluminazione)  
 11. Altoparlante

 Il videocitofono VOG<sup>5W</sup> è dotato di dispositivo per audiolesi integrato, funzionante solo durante le chiamate videocitofoniche. Inoltre il videocitofono è dotato di due tacche in rilievo, posizionate su lati in corrispondenza dei tasti  e , per permettere agli utenti non vedenti di trovare tramite il tatto la posizione dei due pulsanti.

### 3. FUNZIONE PULSANTI

	1	2	3	4	5	6
Stato	<b>A RIPOSO</b> <i>(videocitofono in stand by)</i>	<b>IN ATTESA RISPOSTA</b> <i>(ricezione della chiamata)</i>	<b>IN FONIA</b> <i>(in comunicazione con altro dispositivo)</i>	<b>INVIO CHIAMATE</b> <i>(riposo e singola pressione sul tasto )</i>	<b>FUNZIONI SECONDARIE</b> <i>(riposo e singola pressione sul tasto )</i>	<b>HOME PAGE</b> <i>(riposo e doppia pressione sul tasto )</i>
Tasto						
	Apriporta pedonale (*)	Apriporta pedonale (*)	Apriporta pedonale (*)	Apriporta pedonale (*)	Apriporta pedonale (*)	---
	Funzione "MUTE"	---	---	---	---	---
	(Vai allo stato "INVIO CHIAMATE", vedi colonna 4)	Attivazione della fonia	Se premuto nella modalità di funzionamento: A) "Mani libere" termina la conversazione; B) in "Push to talk": - se premuto a lungo abilita la fonia verso il posto esterno; - se premuto brevemente attiva o termina la conversazione.	---	(Vai allo stato "INVIO CHIAMATE", vedi colonna 4)	Conferma della selezione
	(Vai allo stato "FUNZIONI SECONDARIE", vedi colonna 5)	Accesso o uscita dal menu OSD	Accesso o uscita dal menu OSD	Accesso alla rubrica contatti	(Vai allo stato "HOME PAGE", vedi colonna 6)	Chiusura della Homepage e spegnimento del display
	---	Apriporta passo carraio	Apriporta passo carraio	---	Apriporta passo carraio	---
	---	Funzione Yokis programmabile (default programmato sul canale 1)	Funzione Yokis programmabile (default programmato sul canale 1)	---	Funzione Yokis programmabile (default programmato sul canale 1)	---
	---	Funzione Yokis programmabile (default programmato sul canale 2)	Funzione Yokis programmabile (default programmato sul canale 2)	---	Funzione Yokis programmabile (default programmato sul canale 2)	---

Stato Tasto	A RIPOSO (videocitofono in stand by)	IN ATTESA RISPOSTA (ricezione della chiamata)	IN FONIA (in comunicazione con altro dispositivo)	INVIO CHIAMATE (riposo e singola pressione sul tasto  )	FUNZIONI SECONDARIE (riposo e singola pressione sul tasto  )	HOME PAGE (riposo e doppia pressione sul tasto  )
	---	Accesso alla pagina dei pulsanti Yokis	Accesso alla pagina dei pulsanti Yokis	---	Accesso alla pagina dei pulsanti Yokis	---
	---	Palleggiamento video o visualizzazione di eventuali telecamere aggiuntive delle postazioni di chiamata	---	---	Autoinserzione	---
	---	Funzione Speciale (default codice 07)	Funzione Speciale (default codice 07)	---	Funzione Speciale (default codice 07)	---
	---	---	---	Chiamata intercomunicante programmabile (default: non programmato)	---	---
	---	All'interno del menu OSD decrementa il valore del parametro	All'interno del menu OSD decrementa il valore del parametro	---	---	Scorrimento selezione verso sinistra
	---	All'interno del menu OSD incrementa il valore del parametro	All'interno del menu OSD incrementa il valore del parametro	---	---	Scorrimento selezione verso destra
	---	All'interno del menu OSD permette lo scorrimento dei parametri verso l'alto	All'interno del menu OSD permette lo scorrimento dei parametri verso l'alto	---	---	Scorrimento selezione verso l'alto
	---	All'interno del menu OSD permette lo scorrimento dei parametri verso il basso	All'interno del menu OSD permette lo scorrimento dei parametri verso il basso	---	---	Scorrimento selezione verso il basso
	---	---	---	Chiamata al centralino	---	---

(\*) Su alcune postazioni di chiamata è necessario abilitare il parametro "FUNZIONE APRIPORTA AUTOMATICO" per poter abilitare la funzione di apriporta automatico sul videocitofono (vedere libretti a corredo prodotto).

## 4. PRESTAZIONI

Alcune delle seguenti prestazioni possono essere effettuate anche tramite i comandi gestuali (Gesture). Per maggiori informazioni fare riferimento alla **“Guida rapida per i comandi gestuali”** a corredo prodotto.

### 4.1. RICEZIONE E RISPOSTA A UNA CHIAMATA DA POSTAZIONE DI CHIAMATA



Alla ricezione di una chiamata, il videocitofono squilla e accende il display. Il videocitofono visualizza sul display l'immagine del chiamante. Se nell'appartamento sono presenti più videocitofoni quando si riceve una chiamata solo il videocitofono Master visualizza l'immagine del chiamante. Per visualizzare l'immagine del chiamante su un dispositivo Slave è necessario premere il tasto .

Premendo il tasto  si entra in comunicazione con il chiamante (il led del tasto inizia a lampeggiare).

Premendo nuovamente il tasto la comunicazione viene chiusa e il display si spegne.

### 4.4. FUNZIONE DI APRIPORTA

Il videocitofono consente l'apertura della porta pedonale o passo carraio della postazione di chiamata. Con il videocitofono a riposo<sup>(\*)</sup> o in attesa risposta<sup>(\*)</sup> (ricevuta dalla postazione di chiamata) o in fonìa<sup>(\*)</sup> oppure durante un'autoinserzione<sup>(\*)</sup> (con la postazione di chiamata), è possibile aprire:





- la porta pedonale premendo il tasto 
- il passo carraio premendo il tasto 

(\*) In funzione della tipologia di programmazione dell'apriporta: libero o sotto segreto.

### 4.5. CHIAMATA AL CENTRALINO O CHIAMATA INTERCOMUNICANTE

#### CHIAMATA AL CENTRALINO

Questa funzione permette di entrare in comunicazione con il centralino di portineria.

Per effettuare una chiamata procedere nel seguente modo: con il videocitofono nella condizione di **“RIPOSO”** premere il tasto , i tasti  e  si accenderanno con luce fissa, premere il tasto  per avviare la chiamata.

Se entro 10 secondi non vi è risposta alla chiamata verrà generato dal videocitofono un tono di dissuasione (2 beep) e la chiamata verrà memorizzata nel centralino.

Se il centralinista risponde alla chiamata si entra in comunicazione, sul videocitofono il led del tasto  inizia a lampeggiare e il display del videocitofono visualizza la seguente schermata:

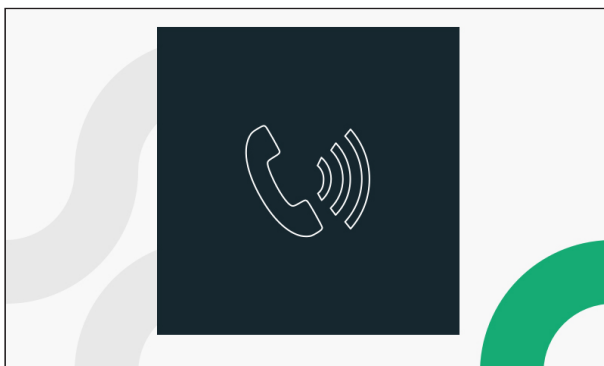





Premendo il tasto  la comunicazione viene chiusa e il display si spegne.

## CHIAMATA INTERCOMUNICANTE

Questa funzione permette di effettuare una chiamata intercomunicante verso un altro posto interno. È possibile avviare una chiamata intercomunicante in 2 modalità:

### 1. DA TASTO INTERCOMUNICANTE

In questa modalità è possibile effettuare una chiamata intercomunicante verso un solo contatto (posto interno) associato al tasto intercomunicante (per tutti i dettagli sulla modalità di associazione vedere il **Libretto di configurazione parametri** al capitolo “**Assegnazione pulsante di chiamata**”).





Con il videocitofono nella condizione di “**RIPOSO**” premere il tasto , i tasti  e  si accenderanno con luce fissa, premere il tasto  per avviare la chiamata intercomunicante.

Quando si entra in comunicazione con il posto interno chiamato, il led del tasto  inizia a lampeggiare.

Premendo nuovamente il tasto  la comunicazione viene chiusa.

### 2. DA RUBRICA



In questa modalità è possibile effettuare una chiamata intercomunicante verso tutti i contatti (posti interni) presenti nella rubrica videocitofonica (per tutti i dettagli su come aggiungere un contatto nella rubrica videocitofonica vedere il **Libretto di configurazione parametri** al capitolo “**Rubrica videocitofonica**”).

Con il videocitofono nella condizione di “**RIPOSO**” premere il tasto , i tasti  e  si accenderanno con luce fissa, premere il tasto  per aprire la rubrica videocitofonica.

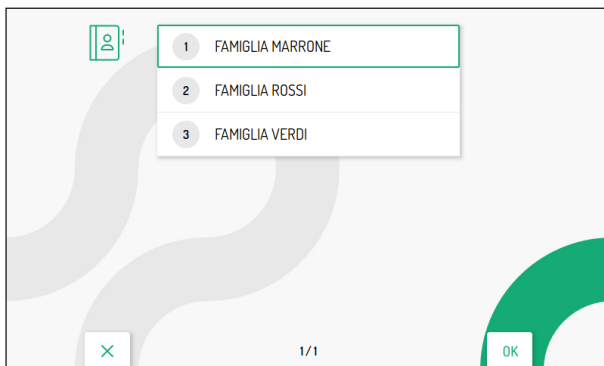
Il display visualizzerà la seguente schermata:



 Per i soli videocitofoni configurati con la modalità di utilizzo **Condominio e Palazzina**, l'accesso alla rubrica videocitofonica è consentito solamente ad un solo dispositivo alla volta, per un tempo massimo di 5 minuti. Nel caso un utente provi ad accedere alla rubrica quando è già in uso su un altro dispositivo, il videocitofono emetterà un tono di dissuasione (4 beep) a indicare che non è possibile visualizzare momentaneamente la rubrica.

Premere i tasti  o  per selezionare il contatto in rubrica da chiamare, successivamente premere il tasto  per avviare la chiamata.

Il display visualizza la seguente schermata:

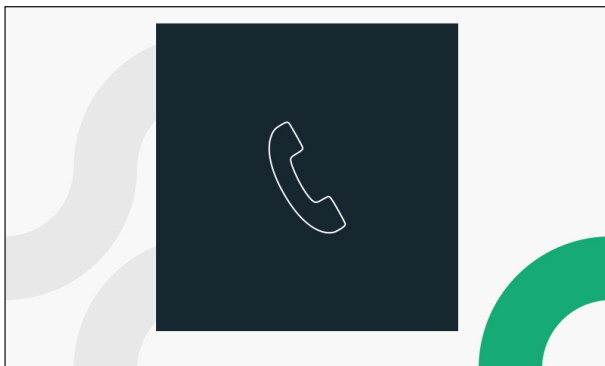

Quando si entra in comunicazione con il posto interno chiamato, il led del tasto  inizia a lampeggiare e se il videocitofono è in modalità **Alimentazione locale** il display visualizza la seguente schermata:

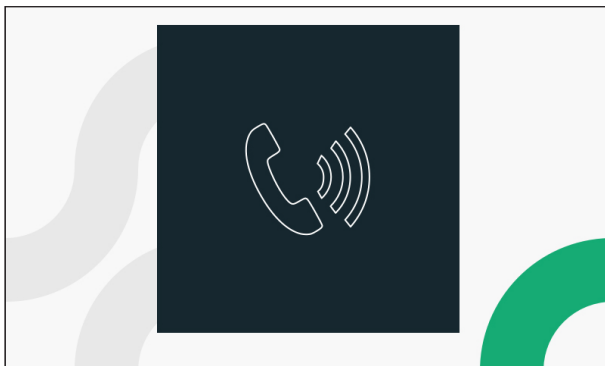

Premendo nuovamente il tasto  la comunicazione viene chiusa.

## 5. LIBRETTO UTENTE COMPLETO

Per tutte le informazioni sull'utilizzo del videocitofono, scaricare il "**Libretto utente**" scansionando il seguente QR Code con la fotocamera del proprio smartphone o tablet.



# ENGLISH

## 1. DESCRIPTION

The video door phones VOG<sup>5W</sup> Ref. 1760/15 and Ref. 1760/16 are dedicated to use in 2Voice video door phone systems.

## 2. DESCRIPTION OF COMPONENTS AND FEATURES

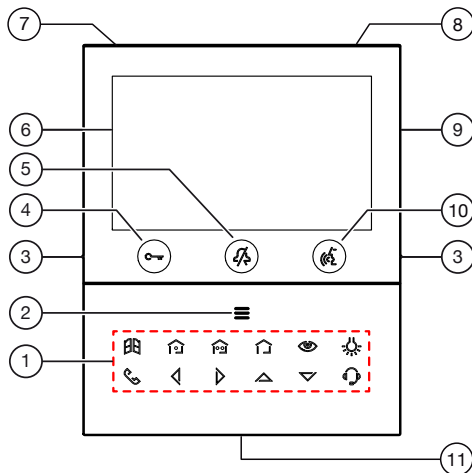

### 1. Function keys:

 : driveway gate door opener key

 : Yokis 1 command setting key

 : Yokis 2 command setting key

 : Yokis key menu key

 : auto-on / video switching key

 : special function key

 : intercom call key

 : left scrolling arrow key

 : right scrolling arrow key

 : upwards scrolling arrow key

 : downwards scrolling arrow key

 : switchboard call key

2. Key for activation of secondary functions / display turning on  (with green backlighting LED)

3. Raised notches for vision-impaired

4. Pedestrian door opener button  (with green / red backlighting LED)

5. Function button  (with red backlighting LED)

6. 5" display

7. Microphone



8. IR sensor for gesture commands

9. Micro SD slot

























10. Audio on/off button  (with green backlighting LED)

11. Speaker

 The VOG<sup>SW</sup> video door phone is provided with a built-in hearing aid device, which only works during video calls. Furthermore, the video door phone is equipped with two raised notches, positioned on the sides next to the buttons  and  to help vision-impaired users locate the position of the two buttons by touch.

### 3. BUTTON FUNCTIONS

	1	2	3	4	5	6
<b>State</b>	<b>STAND-BY</b>  (video door phone in stand-by mode)	<b>WAITING FOR AN ANSWER</b>  (receiving call)	<b>IN VOICE MODE</b>  (communicating with another device)	<b>SENDING CALLS</b>  (stand-by and key  pressed once)	<b>SECONDARY FUNCTIONS</b>  (stand-by and key  pressed once)	<b>HOMEPAGE</b>  (stand-by and key  pressed twice)
<b>Button</b>						
	Open pedestrian door (*)	Open pedestrian door (*)	Open pedestrian door (*)	Open pedestrian door (*)	Open pedestrian door (*)	---
	"MUTE" Function	---	---	---	---	---
	(Go to "SENDING CALLS" status, refer to column 4)	Activate audio	If pressed: A) in "hands-free" operating mode, ends conversation B) in "Push to talk" operating mode: - hold pressed to enable audio with door unit - press briefly to start or end conversation.	---	(Go to "SENDING CALLS" status, refer to column 4)	Confirm selection
	(Go to "SECONDARY FUNCTIONS" status, refer to column 5)	Access or exit the OSD menu	Access or exit the OSD menu	Access the address book	(Go to "HOMEPAGE" status, refer to column 6)	Close the Homepage and turn off the display
	---	Garage door opener	Garage door opener	---	Garage door opener	---
	---	Programmable Yokis function (default programmed on channel 1)	Programmable Yokis function (default programmed on channel 1)	---	Programmable Yokis function (default programmed on channel 1)	---
	---	Programmable Yokis function (default programmed on channel 2)	Programmable Yokis function (default programmed on channel 2)	---	Programmable Yokis function (default programmed on channel 2)	---

State Button	STAND-BY (video door phone in stand-by mode)	WAITING FOR AN ANSWER (receiving call)	IN VOICE MODE (communicating with another device)	SENDING CALLS (stand-by and key  pressed once)	SECONDARY FUNCTIONS (stand-by and key  pressed once)	HOME PAGE (stand-by and key  pressed twice)
	---	Access to the Yokis buttons page	Access to the Yokis buttons page	---	Access to the Yokis buttons page	---
	---	Video switching or displaying of any additional call station cameras.	---	---	Auto-on	---
	---	Special function (default code 07)	Special function (default code 07)	---	Special function (default code 07)	---
	---	---	---	Programmable intercom call 1 (Default: not programmed)	---	---
	---	Within the OSD menu, it decreases the parameter value	Within the OSD menu, it decreases the parameter value	---	---	Scroll selection to the left
	---	Within the OSD menu, it increases the parameter value	Within the OSD menu, it increases the parameter value	---	---	Scroll selection to the right
	---	In the OSD menu, it allows scrolling parameters upwards	In the OSD menu, it allows scrolling parameters upwards	---	---	Scroll selection upwards
	---	In the OSD menu, it allows scrolling parameters downwards	In the OSD menu, it allows scrolling parameters downwards	---	---	Scroll selection downwards
	---	---	---	Exchange call	---	---

(\*) The "AUTOMATIC DOOR OPENER FUNCTION" parameter must be enabled on some calling stations to activate the automatic door opener function on the video door phone (see product manuals).

## 4. FEATURES

Some of the following features can also be performed through gestures.

For more information, refer to the “**Quick guide for gestures**” supplied with the product.

### 4.1. RECEIVING AND ANSWERING A CALL FROM A CALLING STATION



The video door phone will ring and the display will switch on when a call is received. The caller's image will appear on the video door phone display. If there are more than one video door phone in the apartment when a call is received, only the Master video door phone will display the caller's image. To view the caller's image, on a Slave video door phone, press key .

Press the key  to establish a conversation with the caller (the LED of the key will start flashing).

Press the key again to terminate the call and the display switches off.

### 4.4. DOOR OPENER FUNCTION

The video door phone allows the opening of any pedestrian door or garage door associated with the calling station. With the video door phone at rest <sup>(\*)</sup> receiving a call <sup>(\*)</sup> (received from the calling station), in voice mode <sup>(\*)</sup> or during an auto-on event <sup>(\*)</sup> (with the calling station), it is possible to open:





- the pedestrian door by pressing 
- the garage door by pressing 

*(\*) According to how the door opener is programmed: free or secret.*

### 4.5. SWITCHBOARD CALL OR INTERCOM CALL

#### SWITCHBOARD CALL

This function allows to establish a conversation with the gatekeeper lodge switchboard.

Proceed as follows to make a call: with the video door phone in “**STAND-BY**” mode press the key , the keys  and  will turn on with steady light, press the key  to start the call.

If there is no answer to the call within 10 seconds, the video door phone will generate a dissuasion tone (2 beeps) and the call will be saved in the switchboard.

If the switchboard operator answers the call the conversation is established, the LED of key  on the video door phone starts flashing and the video door phone displays the following screen:

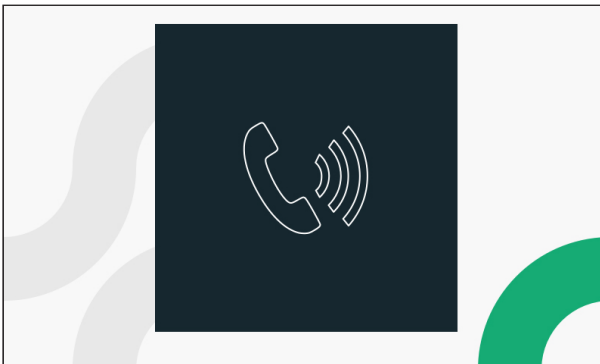

Press the key  to terminate the call and the display switches off.





## INTERCOM CALL

This function allows to make an intercom call to another indoor station.

It is possible to start an intercom call in 2 ways:

### 1. FROM INTERCOM KEY

In this mode it is possible to make an intercom call to one contact only (indoor station) assigned to the intercom key (for all details about the assignment method, see the **Parameter configuration booklet** chapter “**Assigning call key**”).





With video door phone in “**STAND-BY**” mode press key , keys  and  will turn steady on, press key  to start the intercom call.

When conversation with the indoor station has been established, the LED of key  starts flashing.

Press the key  again to terminate the call.

### 2. FROM VIDEO DOOR PHONE BOOK



In this mode it is possible to make an intercom call to all contacts (indoor stations) available in the video door phone book (for all details on how to add a contact to the video door phone book, see the **Parameter configuration booklet** chapter “**Video door phone book**”).

With video door phone in “**STAND-BY**” mode press key , keys  and  turn steady on, press key  to open the video door phone book.

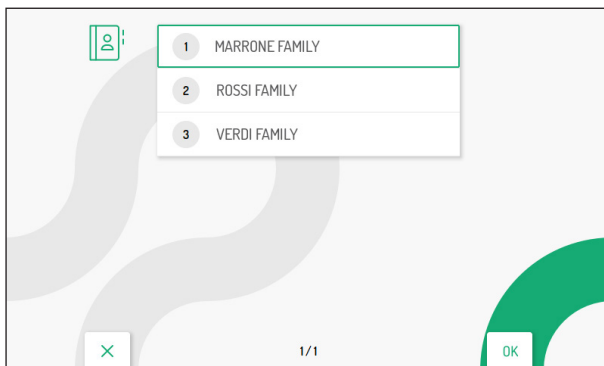
The display shows the following screen page:



 Only for video door configured powered in **Low rise block** and **High rise block** modes, access to the video door phone book is permitted to one device at a time, for a maximum of 5 minutes. If a user tries to access the book when it is already used on another device, the video door phone will emit a dissuasion tone (4 beeps) indicating that the book cannot be displayed at the moment.

Press keys  or  to select the contact in the book to be called, then press the key  to start the call.

The display shows the following screen:

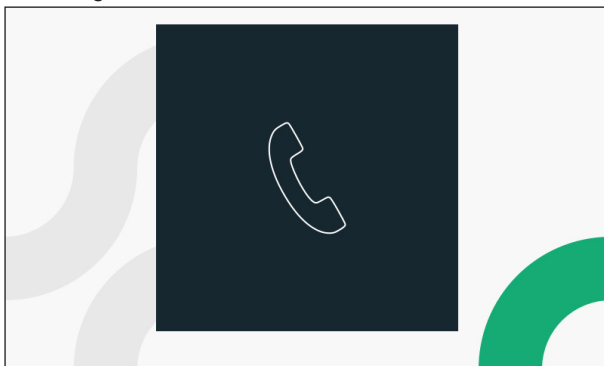

When conversation with the indoor station has been established, the LED of key  starts flashing and if the video door phone is in **Local power** mode the display shows the following screen:

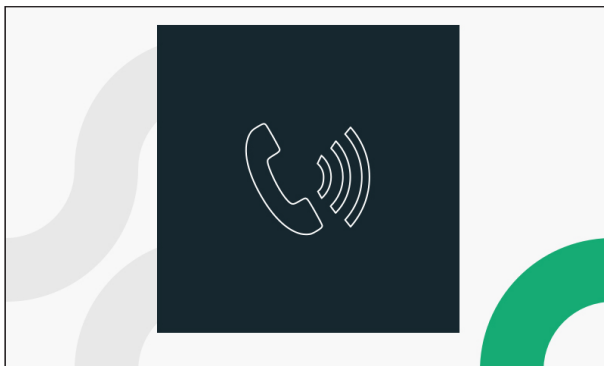

Press the key  again to terminate the call.

## 5. COMPLETE USER HANDBOOK

For all information on use of the video door phone, download the “*User booklet*” by scanning the following QR Code with the camera of your smartphone or tablet.



# FRANÇAIS







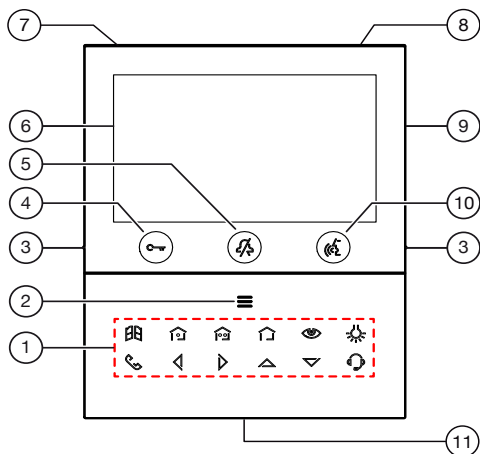



## 1. DESCRIPTION GÉNÉRALE



Les moniteurs VOG 5W Réf. 1760/15 et Réf. 1760/16 sont dédiés à l'utilisation du système 2Voice dans les systèmes de portiers vidéo.

## 2. DESCRIPTION DES COMPOSANTS ET CARACTÉRISTIQUES





### 1. Touches fonctions :











-  : touche ouvre-porte de la porte cochère
-  : touche activation commande Yokis 1
-  : touche activation commande Yokis 2
-  : touche menu boutons Yokis
-  : touche activation automatique / renvoi vidéo
-  : touche fonction spéciale
-  : touche appel intercommunicant
-  : touche flèche défilement à gauche
-  : touche flèche défilement à droite
-  : touche flèche défilement en haut
-  : touche flèche défilement en bas
-  : touche appel à la centrale













- 2. Touche d'activation des fonctions secondaires / allumage de l'écran  (avec LED verte d'éclairage de fond)
- 3. Encoches en relief malvoyants
- 4. Bouton ouvre-porte piétons  (avec LED verte / rouge de rétro-éclairage)
- 5. Touche fonction "MUTE"  (avec LED de rétro-éclairage rouge)
- 6. Afficheur 5"
- 7. Microphone
- 8. Capteur IR pour commandes gestuelles

9. Emplacement microSD  
 10. Bouton d'activation/désactivation phonie  (avec LED verte de rétro-éclairage)  
 11. Haut-parleur

 Le moniteur VOG<sup>5W</sup> est doté d'un dispositif pour les utilisateurs malentendants, qui fonctionne uniquement lors des appels vidéo. Par ailleurs, deux encoches en relief, situées de part et d'autre, au niveau des touches  et , permettent aux utilisateurs malvoyants de les repérer au toucher.

### 3. FONCTIONS DES TOUCHES

	1	2	3	4	5	6
État	<b>REPOS</b> <i>(vidéophone en standby)</i>	<b>EN ATTENTE DE RÉPONSE</b> <i>(réception de l'appel)</i>	<b>EN PHONIE</b> <i>(en communication avec un autre dispositif)</i>	<b>ENVOI D'APPELS</b> <i>(repos et un seul appui sur la touche )</i>	<b>FONCTIONS SECONDAIRES</b> <i>(repos et un seul appui sur la touche )</i>	<b>PAGE D'ACCUEIL</b> <i>(repos et appui double sur la touche )</i>
Touche						
	Ouvre-porte piétons (*)	Ouvre-porte piétons (*)	Ouvre-porte piétons (*)	Ouvre-porte piétons (*)	Ouvre-porte piétons (*)	---
	Fonction "MUTE"	---	---	---	---	---
	(Aller à l'état « ENVOI D'APPELS », voir colonne 4)	Activation de la phonie	Si enfoncé en mode de fonctionnement: A) "Mains-libres" met fin à la conversation; B) dans "Push to talk": — si enfoncé de manière prolongée, habilite la phonie vers le poste externe; — si enfoncé brièvement, active ou met fin à la conversation.	---	(Aller à l'état « ENVOI D'APPELS », voir colonne 4)	Confirmation de la sélection
	(Aller à l'état « FONCTIONS SECONDAIRES », voir colonne 5)	Accès ou sortie du menu OSD	Accès ou sortie du menu OSD	Accès au répertoire des contacts	(Aller à l'état « PAGE D'ACCUEIL », voir colonne 6)	Fermeture de la page d'accueil et extinction de l'écran
	---	Ouverture passage pour véhicules	Ouverture passage pour véhicules	---	Ouverture passage pour véhicules	---
	---	Fonction Yokis programmable (par défaut programmé sur le canal 1)	Fonction Yokis programmable (par défaut programmé sur le canal 1)	---	Fonction Yokis programmable (par défaut programmé sur le canal 1)	---
	---	Fonction Yokis programmable (par défaut programmé sur le canal 2)	Fonction Yokis programmable (par défaut programmé sur le canal 2)	---	Fonction Yokis programmable (par défaut programmé sur le canal 2)	---

État Touche	REPOS (vidéophone en standby)	EN ATTENTE DE RÉPONSE (réception de l'appel)	EN PHONIE (en communication avec un autre dispositif)	ENVOI D'APPELS (repos et un seul appui sur la touche  )	FONCTIONS SECONDAIRES (repos et un seul appui sur la touche  )	PAGE D'ACCUEIL (repos et appui double sur la touche  )
	---	Accès à la page des boutons Yokis	Accès à la page des boutons Yokis	---	Accès à la page des boutons Yokis	---
	---	Renvoi vidéo ou affichage des éventuelles caméras supplémentaires des postes d'appel	---	---	Activation automatique	---
	---	Fonction spéciale (par défaut: code 07)	Fonction spéciale (par défaut: code 07)	---	Fonction spéciale (par défaut: code 07)	---
	---	---	---	Appel intercom 3 programmable (par défaut: non programmé)	---	---
	---	Dans le menu OSD, cela diminue la valeur du paramètre	Dans le menu OSD, cela diminue la valeur du paramètre	---	---	Défilement sélection à gauche
	---	Dans le menu OSD, cela augmente la valeur du paramètre	Dans le menu OSD, cela augmente la valeur du paramètre	---	---	Défilement sélection à droite
	---	Dans le menu OSD permet le défilement en haut des paramètres	Dans le menu OSD permet le défilement en haut des paramètres	---	---	Défilement sélection en haut
	---	Dans le menu OSD permet le défilement en bas des paramètres	Dans le menu OSD permet le défilement en bas des paramètres	---	---	Défilement sélection en bas
	---	---	---	Appel au standard	---	---

(\*) Sur certains postes d'appel, il est nécessaire d'activer le paramètre « FONCTION OUVRE-PORTE AUTOMATIQUE » pour activer la fonction d'ouvre-porte automatique sur le vidéophone (voir les notice fournis avec le produit).



## 4. PERFORMANCES

Certains des avantages suivants peuvent également être effectués via des commandes gestuelles (Gesture). Pour plus d'informations, reportez-vous au « **Guide rapide aux commandes gestuelles** » fourni avec le produit.

### 4.1. RÉCEPTION ET RÉPONSE À UN APPEL DEPUIS UN POSTE D'APPEL

Lors de la réception d'un appel, le moniteur sonne et allume l'écran. Le moniteur visualise l'image de l'appelant à l'écran. En présence de plusieurs moniteurs dans l'appartement, lors de la réception d'un appel seulement le moniteur Maître visualise l'image de l'appelant.



Pour visualiser l'image de l'appelant sur un dispositif Esclave, il faut appuyer sur la touche  du moniteur concerné.

Appuyer sur la touche  pour établir la communication avec l'appelant (la LED de la touche se met à clignoter).

Une nouvelle pression sur la touche met fin à la communication et l'écran s'éteint.

### 4.2. FONCTION OUVRE-PORTE

Le moniteur autorise l'ouverture de la porte piétonne ou de la porte cochère depuis le poste d'appel. Si le moniteur est au repos(\*) ou en attente de réponse(\*) (reçue depuis le poste d'appel) ou en phonie(\*) ou pendant une activation automatique(\*) (avec le poste d'appel), il est possible d'ouvrir :





- la porte piétonne en appuyant sur la touche 
- la porte cochère en appuyant sur la touche 

(\*) Selon la typologie de programmation de l'ouvre-porte : libre ou sous secret.

### 4.3. APPEL VERS LA CENTRALE OU APPEL INTERCOM

#### APPEL À LA CENTRALE

Cette fonction permet d'établir la communication avec la centrale de conciergerie.

Pour effectuer un appel, procéder de la façon suivante : le moniteur étant en état de « **REPOS** », appuyer sur la touche  , i tasti  et  s'allument avec lumière fixe, appuyer sur la touche  pour passer l'appel.

En l'absence de réponse à l'appel dans les 10 secondes, le moniteur émet une tonalité de dissuasion (2 bips) et l'appel sera enregistré dans la centrale.

Si le standardiste répond à l'appel, la communication est établie, la LED de la touche  du moniteur se met à clignoter et l'écran du moniteur visualise la page-écran suivante :

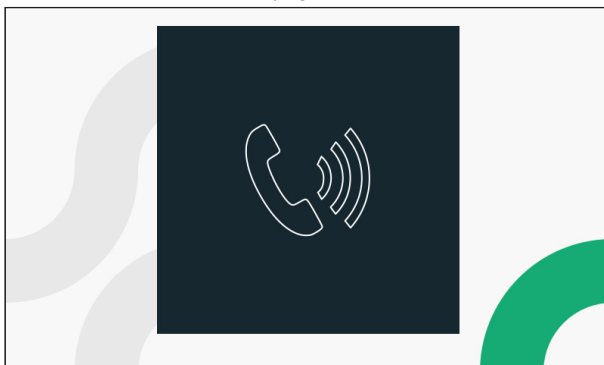





Une pression sur la touche  met fin à la communication et l'écran s'éteint.

## APPEL INTERCOMMUNICANT

Cette fonction permet d'effectuer un appel intercommunicant vers un autre poste interne. Il est possible de passer un appel intercommunicant de 2 façons :

### 1. DEPUIS LA TOUCHE INTERCOMMUNICANTE

Dans ce mode, on peut effectuer un appel intercommunicant vers un seul contact (poste interne) associé à la touche intercommunicante (pour tous les détails sur le mode d'association, se référer au **Notice de configuration des paramètres**, chapitre « **Attribution bouton d'appel** »).

Le moniteur étant en état de « REPOS », appuyer sur la touche  , les touches  et  s'allumeront d'une lumière fixe, appuyer sur la touche  pour passer l'appel intercommunicant.





Une fois la communication établie avec le poste interne appelé, la LED de la touche  se met à clignoter.

En appuyant sur les touches suivantes , ,  et  on peut activer la fonction correspondante (pour plus de détails, se référer au chapitre Fonction boutons).

Appuyer à nouveau sur la touche  pour mettre fin à la communication.

### 2. DEPUIS LE RÉPERTOIRE

Dans ce mode, on peut effectuer un appel intercommunicant vers tous les contacts (postes internes) présents dans le répertoire du moniteur (pour tous les détails sur le mode d'ajouter un contact dans le répertoire du moniteur, se référer au **Notice de configuration des paramètres**, chapitre « **Répertoire du moniteur** »).

Le moniteur étant en état de « REPOS », appuyer sur la touche  , les touches  et  s'allumeront d'une lumière fixe, appuyer sur la touche  pour ouvrir le répertoire du moniteur.

L'écran visualisera la page-écran suivante :

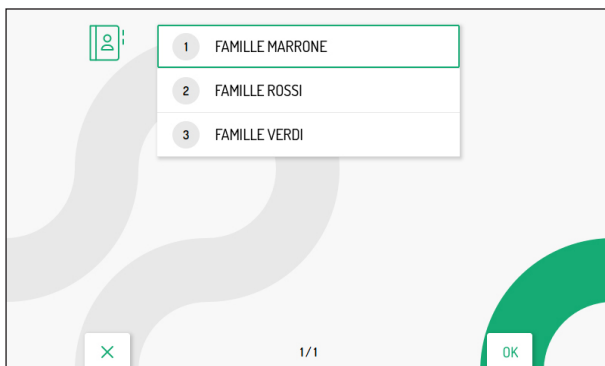

 *Seulement pour les moniteurs configurés dans le mode d'utilisation (**Restreint et Standard**), l'accès au répertoire du moniteur n'est autorisé qu'à un seul dispositif à la fois, pour une durée maximale de 5 minutes. Si un utilisateur essaie d'accéder au répertoire utilisé par un autre dispositif, le moniteur émet une tonalité de dissuasion (4 bips) pour indiquer que l'affichage du répertoire est temporairement impossible.*

Appuyer sur les touches  ou  pour sélectionner le contact du répertoire à appeler, ensuite appuyer sur la touche  pour passer l'appel.

L'écran visualise la page-écran suivante :

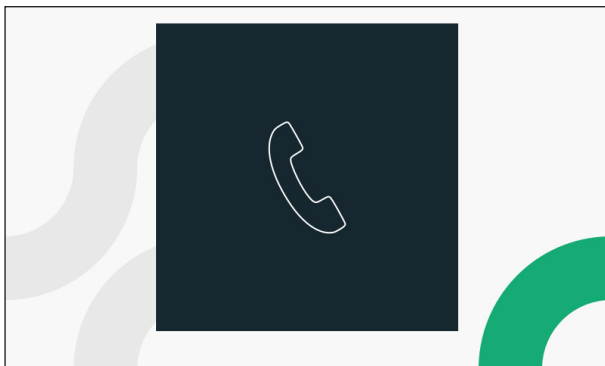

Une fois la communication établie avec le poste interne appelé, la LED de la touche  se met à clignoter et si le moniteur est en mode **Confort** l'écran visualise la page-écran suivante :

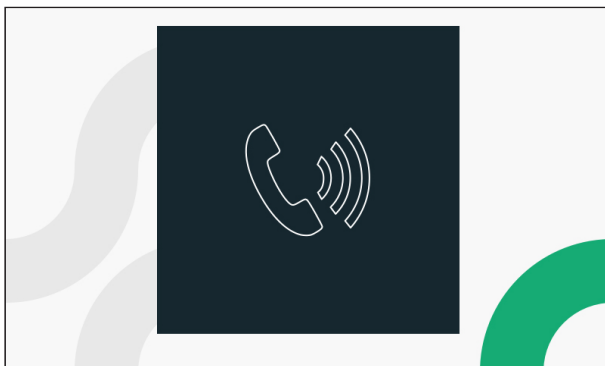

Appuyer à nouveau sur la touche  pour mettre fin à la communication.

## 5. NOTICE UTILISATEUR COMPLÈTE

Pour toutes les informations sur l'utiliser du moniteur, télécharger le "**Notice d'utilisation**" en scannant le QR Code suivant avec la caméra de votre smartphone ou tablette.



# ESPAÑOL

## 1. DESCRIPCIÓN

El videointerfono VOG<sup>5W</sup> Sch. 1760/15 y Sch. 1760/16 está dedicado al uso del sistema 2Voice en sistemas de videointerfonos.

## 2. DESCRIPCIÓN DE LOS COMPONENTES Y CARACTERÍSTICAS

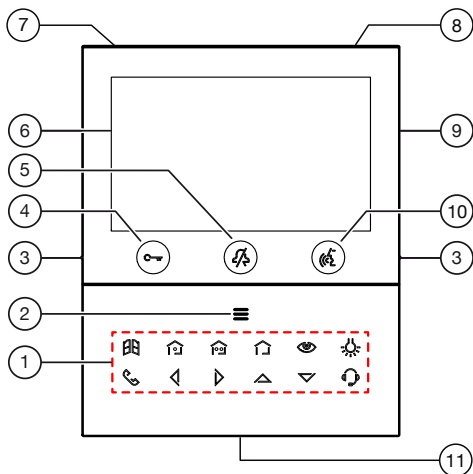



### 1. Teclas función:











- : apertura cancela de acceso
- : tecla activación mando Yokis 1
- : tecla activación mando Yokis 2
- : tecla menú pulsadores Yokis
- : tecla autoencendido / transferencia vídeo
- : tecla función especial
- : tecla llamada intercomunicante
- : tecla flecha desplazamiento hacia la izquierda
- : tecla flecha desplazamiento hacia la derecha
- : tecla flecha desplazamiento hacia arriba
- : tecla flecha desplazamiento hacia abajo
- : tecla llamada a la central













- 2. Tecla para la activación de las funciones secundarias / encendido de la pantalla (con led verde de retroiluminación)
- 3. Raised notches for vision-impaired
- 3. Muecas en relieve por usuarios ciegos
- 4. Pulsador de apertura de la puerta para peatones (con led verde / rojo de retroiluminación)
- 5. Tecla función : función "MUTE" (con led rojo de retroiluminación)
- 6. Pantalla 5"
- 7. Micrófono

8. Sensor IR para mandos gestuales
9. Ranura micro SD
10. Tecla de activación/desactivación de la fonía  (con led verde de retroiluminación)
11. Altavoz

 El videointerfono VOG<sup>5W</sup> tiene incorporado un dispositivo para personas con déficit auditivo, que sólo funciona durante las llamadas videointerfónicas. Además, el videointerfono tiene dos muescas en relieve, colocadas a los lados, en coincidencia con los botones  y , para permitir que los usuarios ciegos encuentren al tacto la posición de los dos pulsadores.

### 3. FUNCIÓN DE LOS PULSADORES

	1	2	3	4	5	6
<b>Estado</b>	<b>EN REPOSO</b> (videoportero en reposo)	<b>EN ESPERA DE RESPUESTA</b> (recepción de la llamada)	<b>EN MODO CONVERSACIÓN</b> (en comunicación con otro dispositivo)	<b>SALIDA LLAMADAS</b> (reposo y una presión de la tecla  )	<b>FUNCIONES SECUNDARIAS</b> (reposo y una presión de la tecla  )	<b>HOME PAGE</b> (reposo y doble presión de la tecla  )
<b>Pulsador</b>						
	Apertura de la puerta para peatones (*)	Apertura de la puerta para peatones (*)	Apertura de la puerta para peatones (*)	Apertura de la puerta para peatones (*)	Apertura de la puerta para peatones (*)	---
	Función "MUTE"	---	---	---	---	---
	(Ir al estado "SALIDA LLAMADAS", ver columna 4)	Actívatelo audio	Si se pulsa en el modo de funcionamiento: A) "Manos libres" termina la conversación; B) en "Push to talk": — si se pulsa de modo prolongado activa la fonía hacia el microaltavoz; — si se pulsa brevemente activa o termina la conversación.	---	(Ir al estado "SALIDA LLAMADAS", ver columna 4)	Confirmar la selección
	(Ir al estado "FUNCIONES SECUNDARIAS", ver columna 5)	Acceso o salida del menú OSD	Acceso o salida del menú OSD	Acceso a la guía de contactos	(Ir al estado "HOME PAGE", ver columna 6)	Cierre de la Homepage y apagamiento de la pantalla
	---	Apertura de la puerta del pasaje de vehículos	Apertura de la puerta del pasaje de vehículos	---	Apertura de la puerta del pasaje de vehículos	---
	---	Función Yokis programable (default programado en el canal 1)	Función Yokis programable (default programado en el canal 1)	---	Función Yokis programable (default programado en el canal 1)	---
	---	Función Yokis programable (default programado en el canal 2)	Función Yokis programable (default programado en el canal 2)	---	Función Yokis programable (default programado en el canal 2)	---

Estado Pulsador	EN REPOSO (videoportero en reposo)	EN ESPERA DE RESPUESTA (recepción de la llamada)	EN MODO CONVERSACIÓN (en comunicación con otro dispositivo)	SALIDA LLAMADAS (reposo y una presión de la tecla  )	FUNCIONES SECUNDARIAS (reposo y una presión de la tecla  )	HOME PAGE (reposo y doble presión de la tecla  )
	---	Acceso a la página de botones de Yokis	Acceso a la página de botones de Yokis	---	Acceso a la página de botones de Yokis	---
	---	Transferencia vídeo o visualización de las cámaras adicionales de los puestos de llamada.	---	---	Autoactivación	---
	---	Función especial (default código 07)	Función especial (default código 07)	---	Función especial (default código 07)	---
	---	---	---	Llamada intercomunicante 1 programable (predeterminado: no programado)	---	---
	---	Dentro del menú OSD disminuye el valor del parámetro	Dentro del menú OSD disminuye el valor del parámetro	---	---	Desplazamiento selección hacia la izquierda
	---	Dentro del menú OSD incrementa el valor del parámetro.	Dentro del menú OSD incrementa el valor del parámetro.	---	---	Desplazamiento selección hacia la derecha
	---	En el menú OSD permite el desplazamiento de los parámetros hacia arriba	En el menú OSD permite el desplazamiento de los parámetros hacia arriba	---	---	Desplazamiento selección hacia arriba
	---	En el menú OSD permite el desplazamiento de los parámetros hacia abajo	En el menú OSD permite el desplazamiento de los parámetros hacia abajo	---	---	Desplazamiento selección hacia abajo
	---	---	---	Llamada a la centralita	---	---

(\*) En algunos videointerfono es necesario activar el parámetro "FUNCIÓN APERTURA PUERTAS AUTOMÁTICA" para poder activar la función de apertura puertas automática en el videointerfono (ver manuales del producto).

## 4. FUNCIONES

Algunas de las siguientes funciones se pueden realizar también mediante los mandos gestuales (Gesture). Para más información consultar la “**Guía rápida de los mandos de gestos**” suministrada con el producto.



### 4.1. RECEPCIÓN Y RESPUESTA A UNA LLAMADA DESDE PUESTO DE LLAMADA

Al recibir una llamada el videoportero suena y activa la pantalla. El videoportero muestra la imagen de quien está llamando en la pantalla. Si el apartamento equipa varios videoporteros, cuando se recibe una llamada solo el videoportero Master muestra la imagen de quien llama. Para visualizar la imagen de quien está llamando en un dispositivo Slave presionar la tecla .

Al presionar la tecla  se activa la comunicación con quien llama (el led de la tecla comienza a parpadear). Al presionar de nuevo la tecla, la comunicación se interrumpe y la pantalla se apaga.

### 4.4. FUNCIÓN DE APERTURA DE LA PUERTA

El videointerfono permite la apertura de la puerta para peatones o pasaje de vehículos asociados al puesto de llamada. Con el videointerfono en reposo<sup>(\*)</sup> en recepción de llamada<sup>(\*)</sup> (recibida desde el puesto de llamada), en fonía<sup>(\*)</sup> durante una autoactivación<sup>(\*)</sup> (con el puesto de llamada), es posible abrir:





- la puerta para peatones pulsando el botón 
- el pasaje para vehículos pulsando el botón 

<sup>(\*)</sup> Según el tipo de programación del dispositivo de apertura de la puerta: libre o con secreto.

### 4.5. LLAMADA A LA CENTRAL O LLAMADA INTERCOMUNICANTE

#### LLAMADA A LA CENTRAL

Esta función permite entrar en comunicación con la central de portería.

Para efectuar una llamada proceder de la siguiente manera: con el videoportero en la condición de “REPOSO” pulsar la tecla , las teclas  y  se encenderán con luz fija, pulsar la tecla  para iniciar la llamada.

Si dentro de 10 segundos no hay respuesta a la llamada el videoportero generará un tono de disuasión (2 bips) y la llamada se memorizará en la central.

Si la central responde a la llamada inicia la comunicación, el led de la tecla  en el videoportero comienza a parpadear y la pantalla del videoportero muestra la siguiente pantalla:

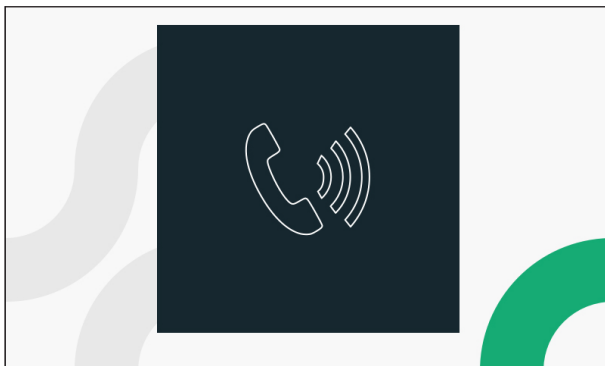





Al presionar la tecla  la comunicación se interrumpe y la pantalla se apaga.



## LLAMADA INTERCOMUNICANTE

Esta función permite efectuar una llamada intercomunicante hacia otro puesto interno. Es posible iniciar una llamada intercomunicante en 2 modalidades:

### 1. CON TECLA INTERCOMUNICANTE





En esta modalidad es posible efectuar una llamada intercomunicante hacia un solo contacto (puesto interno) asociado a la tecla intercomunicante (para todos los detalles en la modalidad de asociación ver el **Manuales de configuración parámetros** en el capítulo “**Asignación pulsador de llamada**”).

Con el videoportero en la condición de “REPOSO” pulsar la tecla , las teclas  y  se encenderán con luz fija, pulsando la tecla  para iniciar la llamada intercomunicante.

Cuando se activa la comunicación con el puesto interno llamado; el led de la tecla  comienza a parpadear. Al presionar de nuevo la tecla  a comunicación se interrumpe.

### 2. CON LA GUÍA



En esta modalidad es posible efectuar una llamada intercomunicante hacia todos los contactos (puestos internos) presentes en la guía del videointerfono (para todos los detalles sobre cómo agregar un contacto en la guía del videointerfono ver el **Manuales de configuración parámetros** en el capítulo “**Guía videointerfono**”).

Con el videoportero en la condición de “REPOSO” pulsar la tecla , las teclas  y  se encenderán con luz fija, pulsar la tecla  para abrir la guía del videointerfono.

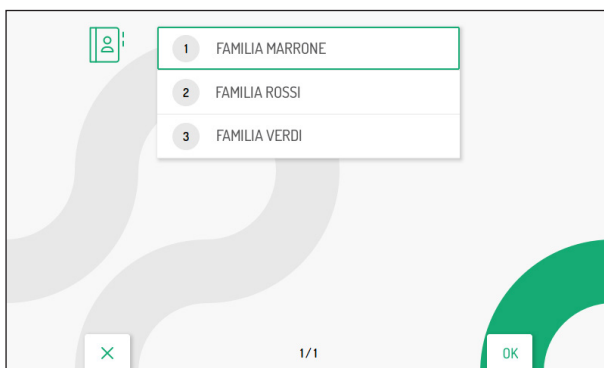
A continuación se muestra la siguiente pantalla:





 Solo para videointerfonos alimentados en modalidad **Condominio** y **Edificio**, el acceso a la guía del videointerfono se permite solo a un dispositivo a la vez, durante un tiempo máximo de 5 minutos. Si un usuario intentara acceder a la guía cuando otro dispositivo ya la está utilizando, el videoportero emitirá un tono de disuasión (4 bips) para indicar que no es posible al momento visualizar la guía.

Pulsar las teclas  o  para seleccionar el contacto en la guía que se desea llamar, luego pulsar la tecla  para iniciar la llamada.

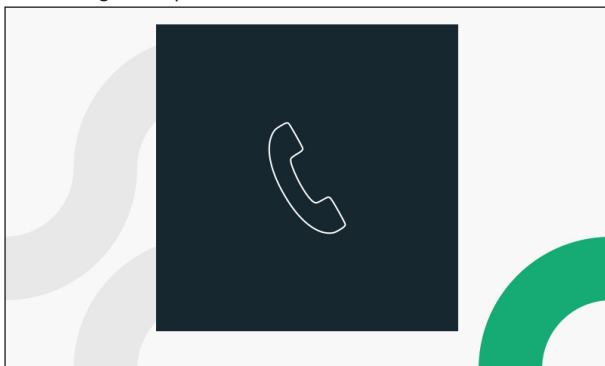

A continuación se muestra la siguiente pantalla:



Cuando se activa la comunicación con el puesto interno llamado; el led de la tecla  comienza a parpadear y, si el videoportero está en modalidad **Alimentación local** la pantalla muestra lo siguiente:

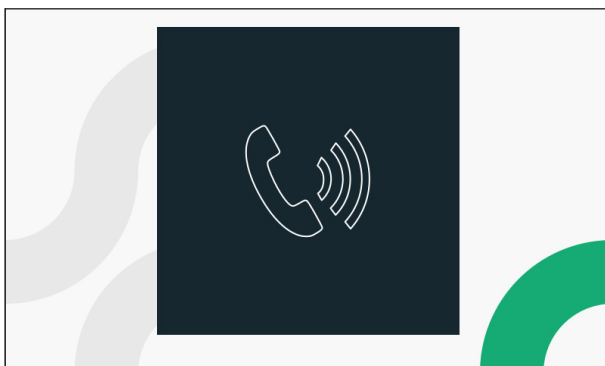

Al presionar de nuevo la tecla  la comunicación se interrumpe.

## 5. MANUAL DE USUARIO COMPLETO

Para obtener toda la información sobre el videoportero y su uso, descargar el “*Manual de usuario*” escaneando el siguiente código QR con la cámara del teléfono móvil o la tableta.



# DEUTSCH

## 1. INHALTSVERZEICHNIS BESCHREIBUNG

Die Videosprechanlagen VOG<sup>SM</sup> BN 1760/15 und BN 1760/16 sind für den Einsatz des 2Voice-Systems in Video-Türsprechanlagen bestimmt.

## 2. GERÄTEBESCHREIBUNG UND MERKMALE

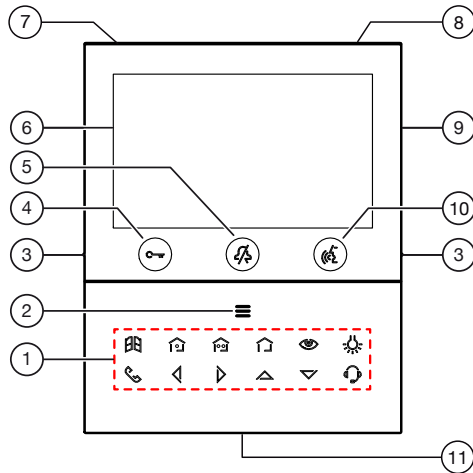



### 1. Funktionstasten:









- : Taste Toröffnung
- : Aktivierungstaste Steuerung Yokis 1
- : Aktivierungstaste Steuerung Yokis 12
- : Menütaste Schaltflächen Yokis
- : Taste Selbststeinschaltung / Videobildübertragung
- : Taste Spezialfunktion
- : Taste Intercom-Anruf
- : Pfeiltaste nach links scrollen
- : Pfeiltaste nach rechts scrollen
- : Pfeiltaste nach oben scrollen
- : Pfeiltaste nach unten scrollen
- : Taste Anruf an Zentrale









- 2. Taste zur Aktivierung der Nebenfunktionen / Display-Einschaltung (mit grüner LED als Hintergrundbeleuchtung)
- 3. Erhobenen Kennzeichnungen blinden Personen
- 4. Türöffnertaste Fußgänger (mit grüner Led / rot als Hintergrundbeleuchtung)
- 5. Taste „MUTE“-Funktion (mit roter Led als Hintergrundbeleuchtung)
- 6. Display 5"
- 7. Mikrofon
- 8. IR-Sensor für Gestensteuerungen

9. Micro-SD-Steckplatz  
 10. Taste zum Aktivieren/Deaktivieren des Gesprächs  (mit grüner Led als Hintergrundbeleuchtung)  
 11. Lautsprecher

 Die Videosprechanlage VOG<sup>5W</sup> ist mit integrierter Einrichtung für Hörgeschädigte ausgestattet, die nur bei Videorufen zugeschaltet wird. Außerdem ist die Videosprechanlage mit zwei erhobenen Kennzeichnungen an den Seiten der Videosprechanlage bei den Tasten  und , ausgestattet, um es blinden Personen zu ermöglichen, die Position der beiden Tasten über den Tastsinn zu finden.

### 3. TASTENFUNKTION

	1	2	3	4	5	6
Status	<b>IM RUHEMODUS</b> <i>(Videosprechanlage in Stand-by)</i>	<b>IM WARTEN AUF BEANTWORTUNG</b> <i>(Empfang des Anrufs)</i>	<b>IM SPRECHKANAL</b> <i>(in Kommunikation mit einem anderen Gerät)</i>	<b>ANRUF SENDEN</b> <i>(Ruhemodus und einmaliges Drücken auf die Taste )</i>	<b>NEBENFUNKTIONEN</b> <i>(Ruhemodus und einmaliges Drücken auf die Taste )</i>	<b>STARTSEITE</b> <i>(Ruhemodus und zweimaliges Drücken auf die Taste )</i>
Taste						
	Türöffnerbefehl (*)	Türöffnerbefehl (*)	Türöffnerbefehl (*)	Türöffnerbefehl (*)	Türöffnerbefehl (*)	---
	"MUTE"-Funktion:	---	---	---	---	---
	(Gehen Sie zum Status "ANRUF SENDEN", siehe Spalte 4)	Sprechkanal freischalten	Bei Betätigung in Betriebsart: A) "Freihand" wird das Gespräch beendet; B) in "Push to talk": - bei langer Betätigung wird das Gespräch mit der Außenstelle aktiviert; - bei kurzer Betätigung wird das Gespräch aktiviert oder beendet.	---	(Gehen Sie zum Status "ANRUF SENDEN", siehe Spalte 4)	Auswahl bestätigen
	(Gehen Sie zum Status "NEBENFUNKTIONEN", siehe Spalte 5)	Zugriff oder Verlassen OSD-Menü	Zugriff oder Verlassen OSD-Menü	Zugriff auf die Kontaktliste	(Gehen Sie zum Status "STARTSEITE", siehe Spalte 6)	Schließen der Startseite und Ausschalten des Displays
	---	Türöffner Einfahrt	Türöffner Einfahrt	---	Türöffner Einfahrt	---
	---	Funktion Yokis programmierbar (standardmäßig programmiert auf Kanal 1)	Funktion Yokis programmierbar (standardmäßig programmiert auf Kanal 1)	---	Funktion Yokis programmierbar (standardmäßig programmiert auf Kanal 1)	---
	---	Funktion Yokis programmierbar (standardmäßig programmiert auf Kanal 2)	Funktion Yokis programmierbar (standardmäßig programmiert auf Kanal 2)	---	Funktion Yokis programmierbar (standardmäßig programmiert auf Kanal 2)	---

Status Taste	IM RUHEMODUS (Video- sprechanlage in Stand-by)	IM WARTEN AUF BEANT- WORTUNG (Empfang des Anrufs)	IM SPRECHKANAL (in Kommunikation mit einem anderen Gerät)	ANRUF SENDEN (Ruhemodus und einmaliges Drücken auf die Taste  )	NEBEN- FUNKTIONEN (Ruhemodus und einmaliges Drücken auf die Taste  )	STARTSEITE (Ruhemodus und zweimaliges Drücken auf die Taste  )
	---	Zugriff auf die Schaltflächenseite von Yokis	Zugriff auf die Schaltflächenseite von Yokis	---	Zugriff auf die Schaltflächenseite von Yokis	---
	---	Videobildübertragung oder Anzeige der eventuell vorhandenen zusätzlichen Kameras der Rufstellen.	---	---	Selbsteinschaltung	---
	---	Spezialfunktion (Standardcode 07)	Spezialfunktion (Standardcode 07)	---	Spezialfunktion (Standardcode 07)	---
	---	---	---	Programmierbarer Intercom-Anruf (Standard: nicht programmiert)	---	---
	---	Verringert den Wert des Parameters im Menü OSD	Verringert den Wert des Parameters im Menü OSD	---	---	Auswahl nach links scrollen
	---	Erhöht den Wert des Parameters im Menü OSD	Erhöht den Wert des Parameters im Menü OSD	---	---	Auswahl nach rechts scrollen
	---	Ermöglicht im OSD-Menü das Scrollen der Parameter nach oben	Ermöglicht im OSD- Menü das Scrollen der Parameter nach oben	---	---	Auswahl nach oben scrollen
	---	Ermöglicht im OSD-Menü das Scrollen der Parameter nach unten	Ermöglicht im OSD- Menü das Scrollen der Parameter nach unten	---	---	Auswahl nach unten scrollen
	---	---	---	Anruf an die Zentrale	---	---

(\*) An einigen Rufstellen muss der Parameter „FUNKTION AUTOMATISCHER TÜRÖFFNER“ freigeschaltet werden, um die Funktion des automatischen Türöffners an der Videosprechanlage freischalten zu können (siehe dem Produkt beiliegende Anleitungen).

## 4. FEATURES

Einige der folgenden Features sind auch über die Gestensteuerung (Gesture) ausführbar. Weitere Informationen finden Sie in der **“Schnellanleitung der Gestensteuerung”**, die dem Produkt beiliegt.

### 4.1. EMPFANG UND BEANTWORTUNG EINES ANRUFES VON EINER RUFSTELLE

Beim Eingang eines Anrufs klingelt die Videosprechanlage und schaltet das Display ein. Die Videosprechanlage zeigt am Display das Bild des Anrufers. Sind in der Wohnung mehrere Videosprechanlagen vorhanden zeigt beim Eingang eines Anrufs nur die MASTER Videosprechanlage das Bild des Anrufers. Zum Anzeigen des Bilds des Anrufers am SLAVE Gerät auf die Taste  drücken.

Durch Betätigen der Taste  wird die Kommunikation dem Anrufer geöffnet (die LED der Taste beginnt zu blinken). Durch erneutes Drücken der Taste wird die Kommunikation beendet und das Display schaltet sich aus.

### 4.4. TÜRÖFFNER-FUNKTION

Die Videosprechanlage ermöglicht das Öffnen der Tür oder des Tors der Rufstelle. Ist die Videosprechanlage im Ruhemodus(\*) oder im Warten auf Beantwortung(\*) (empfangen von der Rufstelle) oder im Gespräch(\*), beziehungsweise während einer Selbsteinschaltung(\*) (mit der Rufstelle), kann man Folgendes öffnen:





- die Tür durch Betätigen der Taste 
- das Tor durch Betätigen der Taste 

(\*) Je nach Programmierung des Türöffners: frei oder geheim..

### 4.5. ANRUF AN ZENTRALE ODER INTERCOM-ANRUF

#### ANRUF AN ZENTRALE

Mit dieser Funktion kann man sich mit der Pförtner-Zentrale in Verbindung setzen.

Zum Anrufen wie folgt verfahren: Bei Videosprechanlage im Status **“RUHE”** auf die Taste  drücken; die Tasten  und  werden sich mit Dauerlicht einschalten; zum Starten des Anrufs die Taste  betätigen.

Erfolgt binnen 10 Sekunden keine Beantwortung des Anrufs, wird von der Videosprechanlage ein Warnton (4 Pieptöne) erzeugt und der Anruf wird in der Zentrale gespeichert.

Antwortet der Telefonist auf den Anruf, wird die Kommunikation geöffnet, die LED der Taste  an der Videosprechanlage beginnt zu blinken und am Display der Videosprechanlage erscheint die folgende Ansicht:

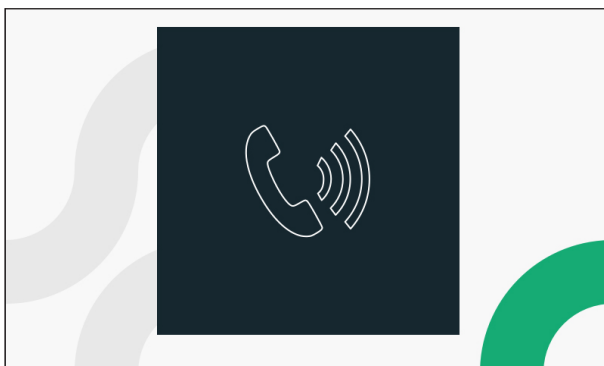





Durch Drücken der Taste  wird die Kommunikation beendet und das Display schaltet sich aus.

## INTERCOM-ANRUF

Mit dieser Funktion kann man einen Intercom-Anruf an eine andere Innenstelle machen.  
Ein Intercom-Anruf lässt sich auf 2 verschiedene Betriebsarten starten:

### 1. ÜBER DIE INTERCOM-TASTE

Bei dieser Betriebsart kann nur ein Intercom-Anruf an nur einen, der Intercom-Taste zugeordneten Kontakt (Innenstelle) gemacht werden (für alle näheren Angaben zum Zuordnungsmodus siehe **Parameterkonfigurations-Anleitung** im Kapitel **“Zuordnung der Anruftaste”**).

Ist die Videosprechanlage im Status “RUHE”, die Taste  betätigen; die Tasten  und  werden sich mit Dauerlicht einschalten; zum Starten des Intercom-Anrufs auf die Taste  drücken.

Wird die Kommunikation mit der angerufenen Innenstelle geöffnet, beginnt die LED der Taste  zu blinken. Durch erneutes Drücken der Taste  wird die Kommunikation beendet.



### 2. ÜBER DIE KONTAKTLISTE

Bei dieser Betriebsart kann ein Intercom-Anruf an alle, in der Kontaktliste der Videosprechanlage befindlichen Kontakte (Innenstellen) gemacht werden (für alle näheren Angaben zur Hinzufügung eines Kontakts in die Kontaktliste der Videosprechanlage siehe **Parameterkonfigurations-Anleitung** im Kapitel **“Kontaktliste der Videosprechanlage”**).

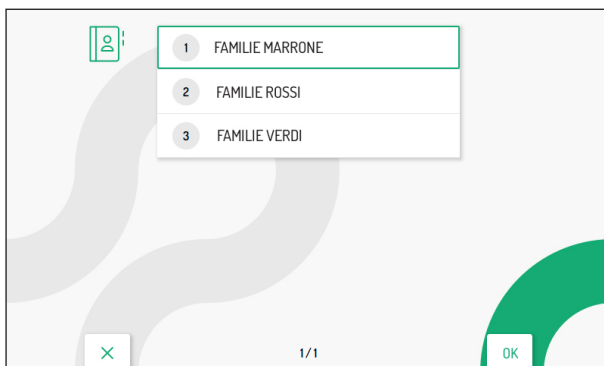
Bei Videosprechanlage im “RUHE-”Status die Taste  betätigen; die Tasten  und  werden sich mit Dauerlicht einschalten; zum Öffnen der Kontaktliste der Videosprechanlage auf die Taste  drücken. Das Display wird folgende Ansicht anzeigen:



 *Nur für Videosprechanlagen mit Betriebsart **Eigentumswohnung** und **Gebäude**: Der Zugriff auf die Kontaktliste der Videosprechanlage ist jeweils nur einem Gerät für eine Dauer von maximal 5 Minuten gestattet. Versucht ein Benutzer auf die Kontaktliste zuzugreifen, wenn sie bereits an einem anderen Gerät verwendet wird, gibt die Videosprechanlage einen Warnton (4 Pieptöne) und weist somit darauf hin, dass die Kontaktliste momentan nicht verwendet werden kann.*

Durch Betätigen der Tasten  oder  den anzurufenden Kontakt in der Kontaktliste wählen, dann zum Starten des Anrufs auf die Taste  drücken.

Das Display zeigt folgende Ansicht an:

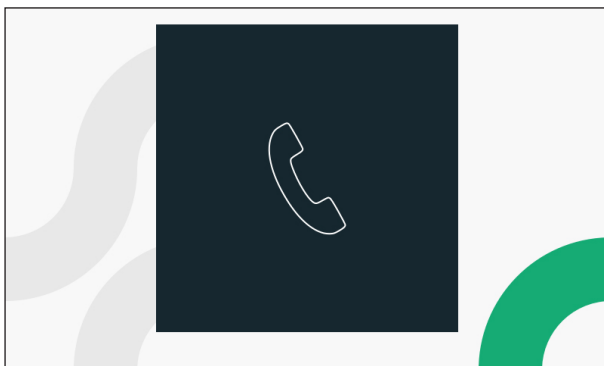

Wird die Kommunikation mit der angerufenen Innenstelle geöffnet, beginnt die LED der Taste  zu blinken, und wenn sich die Videosprechanlage in der Betriebsart **Lokale Stromversorgung** befindet, zeigt das Display die folgende Ansicht an:

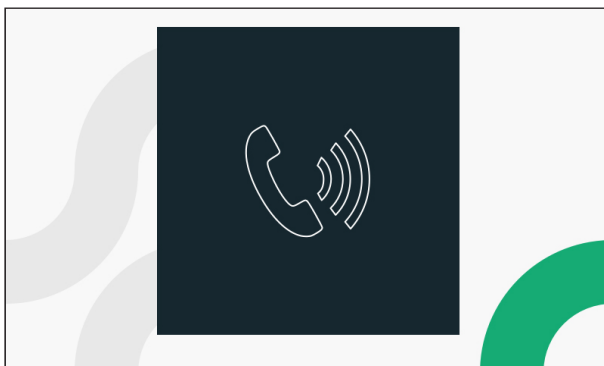

Durch erneutes Drücken der Taste  wird die Kommunikation beendet.

## 5. VOLLSTÄNDIGE BENUTZER-ANLEITUNG

Für alle Informationen zur Verwendung der Videosprechanlage können Sie die **“Benutzer-Anleitung“** herunterladen, indem Sie den folgenden QR-Code mit der Kamera Ihres Smartphones oder Tablets scannen.



# NEDERLANDS

## 1. ALGEMENE BESCHRIJVING

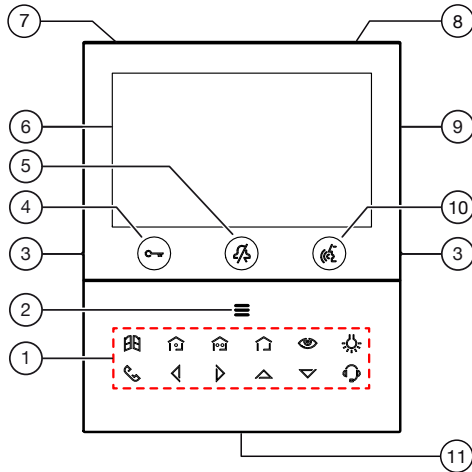

De video-intercoms VOG<sup>5W</sup> Sch. 1760/15 en Sch. 1760/16 zijn speciaal bestemd voor gebruik in 2Voice video-intercomsystemen.

## 2. OMSCHRIJVING EN KENMERKEN VAN DE ONDERDELEN





### 1. Functietoetsen:

-  : toets deuropener oprijpoort
-  : Yokis 1 commando activeringstoets
-  : Yokis 2 commando activeringstoets
-  : Yokis-knoppen menu-toets
-  : automatische activering / videodrifttoets
-  : speciale functietoets
-  : toets intercomoproep
-  : toets pijl naar links scrollen
-  : toets pijl naar rechts scrollen
-  : toets pijl naar boven scrollen
-  : toets pijl naar beneden scrollen
-  : toets oproep naar de receptiecentrale











- 2. Toets voor het activeren van secundaire functies / inschakelen van het display  (met groene achtergrondverlichting led)
- 3. Markeringen in reliëf zodat slechtziende
- 4. Toets voetgangersdeuropener  (met groen led / rood achtergrondverlichtingsled)
- 5. Toets  MUTE-functie;" (met rood led voor achtergrondverlichting)
- 6. Display 5"
- 7. Microfoon
- 8. IR-sensor voor gebarenherkenning















9. Micro SD-slot  
 10. Toets om telefoonfunctie in/uit te schakelen  (met groene led achtergrondverlichting)  
 11. Luidspreker

 De beeldintercom VOG <sup>SW</sup> is uitgerust met een ingebouwde versterker voor slechthorenden die alleen werkt tijdens de beeldintercom-oproepen. Op de beeldintercom zitten bovendien twee markeringen in reliëf aan beide kanten ter hoogte van de toetsen  en  zodat slechthorende gebruikers de toetsen op de tast kunnen vinden.

### 3. WERKING VAN DE TOETSEN

	1	2	3	4	5	6
Status	RUSTSTAND <i>(video-intercom in stand-by)</i>	IN AFWACHTING VAN ANTWOORD <i>(oproep ontvangen)</i>	IN SPRAAK <i>(communiceren met ander toestel)</i>	OPROEPEN VERZENDEN <i>(ruststand en enkele druk op de toets )</i>	SECUNDAIRE FUNCTIES <i>(ruststand en enkele druk op de toets )</i>	HOMEPAGE <i>(ruststand en dubbele druk op de toets )</i>
Toets						
	Voetgangersdeuro (*)	Voetgangersdeuro (*)	Voetgangersdeuro (*)	Voetgangersdeuro (*)	Voetgangersdeuro (*)	---
	"MUTE" functie	---	---	---	---	---
	(Ga naar de status "OPROEPEN VERZENDEN", zie kolom 4)	Gespreksfunctie activeren	Bij het indrukken van: A) "Handenvrije communicatie", eindigt het gesprek; B) in "Push to talk": - indien lang ingedrukt, schakelt dit de gespreksfunctie in naar de buitenpost; - indien kort ingedrukt, activeert of eindigt dit het gesprek.	---	(Ga naar de status "OPROEPEN VERZENDEN", zie kolom 4)	Bevestiging van de keuze
	(Ga naar de status "SECUNDAIRE FUNCTIES", zie kolom 5)	Toegang tot of verlaten van het OSD-menu	Toegang tot of verlaten van het OSD-menu	Toegang tot het telefoonboek	(Ga naar de status "HOMEPAGE", zie kolom 6)	Sluiten van de homepage en uitschakelen van het display
	---	Deuropener inrijpoort	Deuropener inrijpoort	---	Deuropener inrijpoort	---
	---	Yokis-functie programmeerbaar (standaard geprogrammeerd op kanaal 1)	Yokis-functie programmeerbaar (standaard geprogrammeerd op kanaal 1)	---	Yokis-functie programmeerbaar (standaard geprogrammeerd op kanaal 1)	---
	---	Yokis-functie programmeerbaar (standaard geprogrammeerd op kanaal 2)	Yokis-functie programmeerbaar (standaard geprogrammeerd op kanaal 2)	---	Yokis-functie programmeerbaar (standaard geprogrammeerd op kanaal 2)	---

Status Toets	RUSTSTAND <i>(video-intercom in stand-by)</i>	IN AFWACHTING VAN ANTWOORD <i>(oproep ontvangen)</i>	IN SPRAAK <i>(communiceren met ander toestel)</i>	OPROEPEN VERZENDEN <i>(ruststand en enkele druk op de toets )</i>	SECUNDAIRE FUNCTIES <i>(ruststand en enkele druk op de toets )</i>	HOMEPAGE <i>(ruststand en dubbele druk op de toets )</i>
	---	Toegang tot de Yokis-knoppenpagina	Toegang tot de Yokis-knoppenpagina	---	Toegang tot de Yokis-knoppenpagina	---
	---	Bladeren door video's of weergave van eventuele extra camera's op de oproepstations	---	---	Automatische inschakeling	---
	---	Speciale functie (standaardcode 07)	Speciale functie (standaardcode 07)	---	Speciale functie (standaardcode 07)	---
	---	---	---	Chiamata intercomunicante programmabile (default: non programmato)	---	---
	---	In het OSD-menu daalt de waarde van de parameter	In het OSD-menu daalt de waarde van de parameter	---	---	Selectie doorbladeren naar links
	---	In het OSD-menu stijgt de waarde van de parameter	In het OSD-menu stijgt de waarde van de parameter	---	---	Selectie doorbladeren naar rechts
	---	Binnen het OSD-menu is het mogelijk door de parameters naar boven te bladeren	Binnen het OSD-menu is het mogelijk door de parameters naar boven te bladeren	---	---	Selectie doorbladeren naar boven
	---	Binnen het OSD-menu is het mogelijk door de parameters naar beneden te bladeren	Binnen het OSD-menu is het mogelijk door de parameters naar beneden te bladeren	---	---	Selectie doorbladeren naar beneden
	---	---	---	Oproep naar de receptiecentrale	---	---

(\*) Op sommige belstations moet de parameter "AUTOMATISCHE DEUROPENERFUNCTIE" ingeschakeld zijn om de automatische deuropenerfunctie op de video-intercom in te schakelen (zie handleidingen bij het product).

## 4. FUNCTIES

Sommige van de volgende functies kunnen ook met gebaaropdrachten uitgevoerd worden (Gesture). Raadpleeg de “**Beknopte handleiding voor gebaaropdrachten**” bij het product voor meer informatie.

### 4.1. EEN OPROEP ONTVANGEN EN BEANTWOORDEN VANAF HET BELSTATION

Wanneer er een oproep binnenkomt, gaat de video-intercom over en licht het display op. De video-intercom toont de afbeelding van de beller op het display. Indien er meerdere video-intercoms in het appartement zijn, zal alleen de Master-video-intercom het beeld van de beller tonen wanneer er een oproep binnenkomt. Om de weergave van de beller op een Slave-toestel te tonen, drukt u op de toets .

Druk op toets  om met de beller te communiceren (de led van de toets begint te knipperen).

Door nogmaals op de toets te drukken, wordt de communicatie gesloten en wordt het display uitgeschakeld.

### 4.4. DEUROPENERFUNCTIE

Met de video-intercom kan de voetgangersdeur of de oprijpoort vanaf het belstation geopend worden. Met de video-intercom in ruststand(\*) of in afwachting van antwoord(\*) (ontvangen van het belstation) of in spraak(\*) of tijdens een automatische activering(\*) (met het belstation), is het mogelijk om te openen:





- de voetgangersdeur door het indrukken van de toets 
- de oprijpoort door het indrukken van de toets 

(\*) *Afhankelijk van het type programmering van de deuropener: vrij of geheim..*

### 4.5. OPROEP NAAR DE RECEPTIECENTRALE OF INTERCOM-OPROEP

#### OPROEP NAAR DE RECEPTIECENTRALE

Deze functie maakt communicatie met de portiersloge mogelijk.

Om te bellen, gaat u als volgt te werk: met de video-intercom in “**RUST**”-stand, drukt u op de toets , de toetsen  en  gaan branden met een vast lampje, druk op de toets  om het gesprek te beginnen.

Als de oproep niet binnen 10 seconden wordt beantwoord, genereert de video-intercom een geluidssignaal (4 pieptonen) en wordt de oproep in de centrale opgeslagen.

Als de telefonist de oproep beantwoordt, komt de communicatie tot stand; de led op de toets  begint te knipperen en het display van de video-intercom toont het volgende scherm:

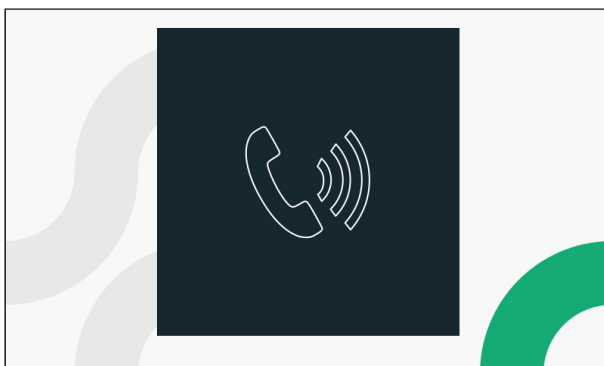





Door op toets  te drukken wordt de communicatie beëindigd en schakelt het display uit.

## INTERCOM-OPROEP

Met deze functie kunt u een intercom-oproep doen naar een ander binnenstation. Een intercom-oproep kan op 2 manieren tot stand gebracht worden:

### 1. VANAF DE INTERCOMTOETS

In deze modus is het mogelijk een intercomoproep te doen naar één enkel contact (binnenstation) dat aan de intercomknop gekoppeld is (raadpleeg voor alle details over de koppelingsmodus het **Configuratieboekje met de parameters** in het hoofdstuk “**Toewijzing van de oproeptoetsen**”).

Met de video-intercom in “RUST”-stand, drukt u op de toets  , de toetsen  en  gaan branden met vast lampje, druk op de toets  om het intercomgesprek te beginnen.

Wanneer de communicatie met het opgeroepen binnenstation tot stand is gebracht, begint de led op de  toets te knipperen.

Druk nogmaals op toets  om de communicatie te beëindigen.

### 2. VANUIT HET TELEFOONBOEK



In deze modus is het mogelijk een intercomoproep te doen naar alle contacten (binnenstations) in het telefoonboek van de video-intercom (raadpleeg voor alle details over het toevoegen van een contact aan het telefoonboek van de video-intercom het **Configuratieboekje met de parameters** in het hoofdstuk “**Telefoonboek van de video-intercom**”).

Met de video-intercom in “RUST”-stand, drukt u op de toets  , de toetsen  en  gaan branden met vast lampje, druk op de toets  om het telefoonboek van de video-intercom te openen.

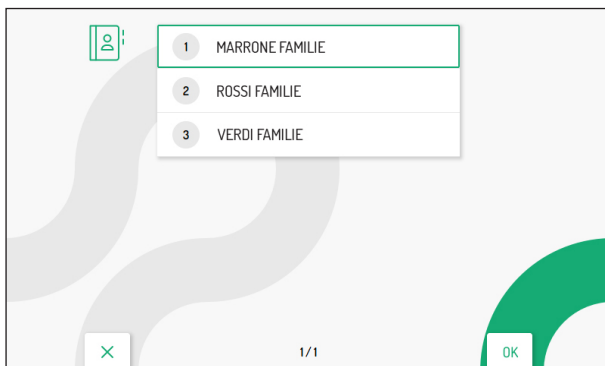
Het display toont het volgende scherm:



 Voor video-intercoms die gevoed worden in de **Gebouw** en **Condominium**-modus, is toegang tot het video-intercomtelefoonboek slechts voor één toestel tegelijk toegestaan, voor een maximale tijd van 5 minuten. Als een gebruiker het telefoonboek probeert te openen terwijl het al in gebruik is op een ander toestel, zal de video-intercom een geluidssignaal (4 pieptonen) afgeven om aan te geven dat het op dat moment niet mogelijk is het telefoonboek weer te geven.

Druk op de toets  of  om het te bellen contact in het telefoonboek te kiezen, en druk dan op de toets  om het gesprek te beginnen.

Het display toont het volgende scherm:

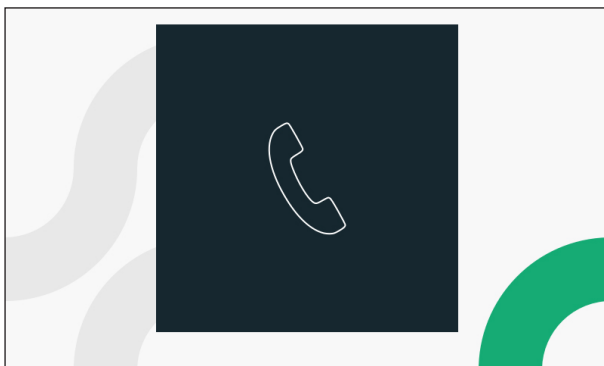

Wanneer de communicatie met opgeroepen binnenstation tot stand is gebracht, begint de led van de toets  te knipperen en als de video-intercom in de **Lokale voeding**-stand staat, toont het display het volgende scherm:

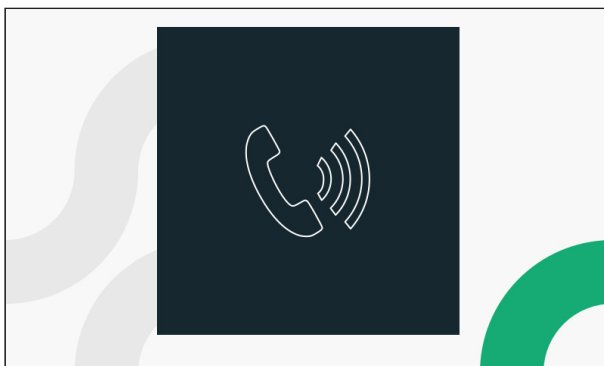

Druk nogmaals op toets  om de communicatie te beëindigen.

## 5. VOLLEDIGE GEBRUIKERSHANDLEIDING

Voor alle informatie over het gebruik van de video-intercom kunt u de "**Gebruiksaanwijzing**" downloaden door de volgende QR-code te scannen met de camera van uw smartphone of tablet.







**DS1760-044**

URMET S.p.A.  
10154 TORINO (ITALY)  
VIA BOLOGNA 188/C  
Telef. +39 011.24.00.000 (RIC. AUT.)  
Fax +39 011.24.00.300 - 323

**urmet**

**LBT21225**

Area tecnica  
servizio clienti +39 011.23.39.810  
<http://www.urmet.com>  
e-mail: [info@urmet.com](mailto:info@urmet.com)